



POWERING INNOVATION THAT DRIVES HUMAN ADVANCEMENT

© 2025 ANSYS, Inc. or its affiliated companies
Unauthorized use, distribution, or duplication is prohibited.

Getting Started with Maxwell®: ECAD Integration



ANSYS, Inc.
Southpointe
2600 Ansys Drive
Canonsburg, PA 15317
ansysinfo@ansys.com
<https://www.ansys.com>
(T) 724-746-3304
(F) 724-514-9494

Release 2025 R1
January 2025

ANSYS, Inc. and
ANSYS Europe,
Ltd. are UL
registered ISO
9001:2015
companies.

Copyright and Trademark Information

© 1986-2025 ANSYS, Inc. Unauthorized use, distribution or duplication is prohibited.

ANSYS, Ansys Workbench, AUTODYN, CFX, FLUENT and any and all ANSYS, Inc. brand, product, service and feature names, logos and slogans are registered trademarks or trademarks of ANSYS, Inc. or its subsidiaries located in the United States or other countries. ICFD is a trademark used by ANSYS, Inc. under license. All other brand, product, service and feature names or trademarks are the property of their respective owners. FLEXlm and FLEXnet are trademarks of Flexera Software LLC.

Disclaimer Notice

THIS ANSYS SOFTWARE PRODUCT AND PROGRAM DOCUMENTATION INCLUDE TRADE SECRETS AND ARE CONFIDENTIAL AND PROPRIETARY PRODUCTS OF ANSYS, INC., ITS SUBSIDIARIES, OR LICENSORS. The software products and documentation are furnished by ANSYS, Inc., its subsidiaries, or affiliates under a software license agreement that contains provisions concerning non-disclosure, copying, length and nature of use, compliance with exporting laws, warranties, disclaimers, limitations of liability, and remedies, and other provisions. The software products and documentation may be used, disclosed, transferred, or copied only in accordance with the terms and conditions of that software license agreement.

ANSYS, Inc. and ANSYS Europe, Ltd. are UL registered ISO 9001: 2015 companies.

U.S. Government Rights

For U.S. Government users, except as specifically granted by the ANSYS, Inc. software license agreement, the use, duplication, or disclosure by the United States Government is subject to restrictions stated in the ANSYS, Inc. software license agreement and FAR 12.212 (for non-DOD licenses).

Third-Party Software

See the legal information in the product help files for the complete Legal Notice for Ansys proprietary software and third-party software. If you are unable to access the Legal Notice, please contact ANSYS, Inc.

Conventions Used in this Guide

Please take a moment to review how instructions and other useful information are presented in this documentation.

- Procedures are presented as numbered lists. A single bullet indicates that the procedure has only one step.
- Bold type is used for the following:
 - Keyboard entries that should be typed in their entirety exactly as shown. For example, “**copy file1**” means you must type the word **copy**, then type a space, and then type **file1**.
 - On-screen prompts and messages, names of options and text boxes, and menu commands. Menu commands are often separated by greater than signs (>). For example, “click **Maxwell 2D > Excitations > Assign > Wave Port.**”
 - Labeled keys on the computer keyboard. For example, “Press **Enter**” means to press the key labeled **Enter**.
- Italic type is used for the following:
 - Emphasis
 - Titles of publications
 - Keyboard entries when a name or a variable must be typed in place of the words in italics. For example, “**copy filename**” means you must type the word **copy**, then type a space, and then type the name of the file.
- The plus sign (+) is used between keyboard keys to indicate that you should press the keys at the same time. For example, “Press Shift+F1” means to press the **Shift** key and, while holding it down, press the **F1** key also. You should always depress the modifier key or keys first (for example, Shift, Ctrl, Alt, or Ctrl+Shift), continue to hold it/them down, and then press the last key in the instruction.

Accessing Commands: *Ribbons*, *menu bars*, and *shortcut menus* are three methods that can be used to see what commands are available in the application.

- The *Ribbon* occupies the rectangular area at the top of the application window and contains multiple tabs. Each tab has relevant commands that are organized, grouped, and labeled. An example of a typical user interaction is as follows:

"Click **Draw > Line**"

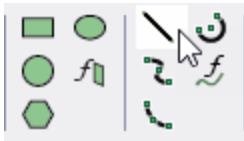

This instruction means that you should click the **Line** command on the **Draw** ribbon tab. An image of the command icon or a partial view of the ribbon is often included with the instruction.

- The *menu bar* (located above the ribbon) is a group of the main commands of an application arranged by category such File, Edit, View, Project, etc. An example of a typical user interaction is as follows:

"On the **File** menu, click the **Open Examples** command" means you can click the **File** menu and then click **Open Examples** to launch the dialog box.

- Another alternative is to use the *shortcut menu* that appears when you click the right-mouse button. An example of a typical user interaction is as follows:

"Right-click and select **Assign Excitation > Wave Port**" means when you click the right-mouse button with an object face selected, you can execute the excitation commands from the shortcut menu (and the corresponding sub-menus).

Getting Help: Ansys Technical Support

For information about Ansys Technical Support, go to the Ansys corporate Support website, <http://www.ansys.com/Support>. You can also contact your Ansys account manager in order to obtain this information.

All Ansys software files are ASCII text and can be sent conveniently by e-mail. When reporting difficulties, it is extremely helpful to include very specific information about what steps were taken or what stages the simulation reached and to include software files as applicable. This allows more rapid and effective debugging.

Help Menu

To access help from the Help menu, click **Help** and select from the menu:

- **[product name] Help** - opens the contents of the help. This help includes the help for the product and its *Getting Started Guides*.
- **[product name] Scripting Help** - opens the contents of the *Scripting Guide*.
- **[product name] Getting Started Guides** - opens a topic that contains links to Getting Started Guides in the help system.

Context-Sensitive Help

To access help from the user interface, press **F1**. The help specific to the active product (design type) opens.

You can press **F1** while the cursor is pointing at a menu command or while a particular window or window tab is open. In this case, the help page associated with the command or open dialog box is displayed automatically.

Table of Contents

Table of Contents	Contents-1
1 - Introduction	1-1
Goals	1-4
2 - Preparing a 3D Layout	2-1
Import the PCB Layout	2-1
Explore Design	2-2
Assign Ports	2-9
Set Up Solution	2-14
Assign a Mesh Operation	2-15
3 - Create the Maxwell 3D A-Phi Transient Design	3-1
Import 3D Layout to Maxwell	3-2
Modify an Imported Layout	3-7
Create Simulation Region	3-8
Assign Excitation	3-9
Specify Initial Mesh for Maxwell	3-11
4 - Generating a Solution	4-1
Add Solution Setup	4-1
Set Up Force Calculation for Layout Component	4-2
Enable Harmonic Force Calculation	4-5
Validate Design and Run Simulation	4-7
5 - Analyzing the Solution	5-1
Plot the Force and Current	5-1
Field Visualization	5-5
Export Harmonic Force Data	5-12
6 - Combining ECAD and MCAD	6-1
Create Permanent Magnet	6-1

Assign Mesh to Magnet and Run Simulation 6-3

View Force and Current Results 6-4

View Field Results on Magnet 6-8

View Field Results on Nets 6-10

7 - Exit the Electronics Desktop 7-1

Index Index-1

1 - Introduction

Ansys Maxwell is an interactive software package that uses finite element analysis (FEA) to simulate (solve) electromagnetic field problems. Maxwell integrates with other Ansys software packages to perform complex tasks while remaining simple to use. This guide will focus on Maxwell's integration with Ansys ECAD, and it will show how to enhance an ECAD design using Maxwell's MCAD tools.

Maxwell can be used for PCB layout analysis. It can calculate noise vibrations at low frequency, so it can be used to do the following:

- Understand how permanent magnets located in proximity of PCB influence the noise
- Reduce noise issues by computing Lorentz forces between traces
- Model deformation and vibrations due to harmonic forces
- Obtain acoustic response of boards resulting from vibrations

PCB layouts can be imported into Maxwell and edited from within the Maxwell interface. This Getting Started Guide will detail the steps required to import and simulate an example layout.

Note: For more details on using 3D layouts in Maxwell, see [3D Transient Solution with an A-Phi Formulation](#).

To analyze a problem, you specify the appropriate geometry, material properties, and excitations for a device or system of devices. The Maxwell software then does the following:

- Automatically creates the required finite element mesh.
- Calculates the desired electric or magnetic field solution and special quantities of interest, such as force, torque, inductance, capacitance, or power loss. The specific types of field solutions and quantities that can be computed depend on which Maxwell 3D solution type you specified (electric fields, DC magnetics, AC magnetics, transient fields and data).
- Allows you to analyze, manipulate, and display field solutions.

For this example, a 3D layout will be imported as a component, so the geometry and material properties will already be defined. Because this model was created in the HFSS 3D Layout tool, it includes layer information, so it is considered a 3D layout. But when it is imported into Maxwell, it is considered as a 3D component.

This design is a power delivery network board; the 3D layout in the HFSS 3D Layout tool is shown below:

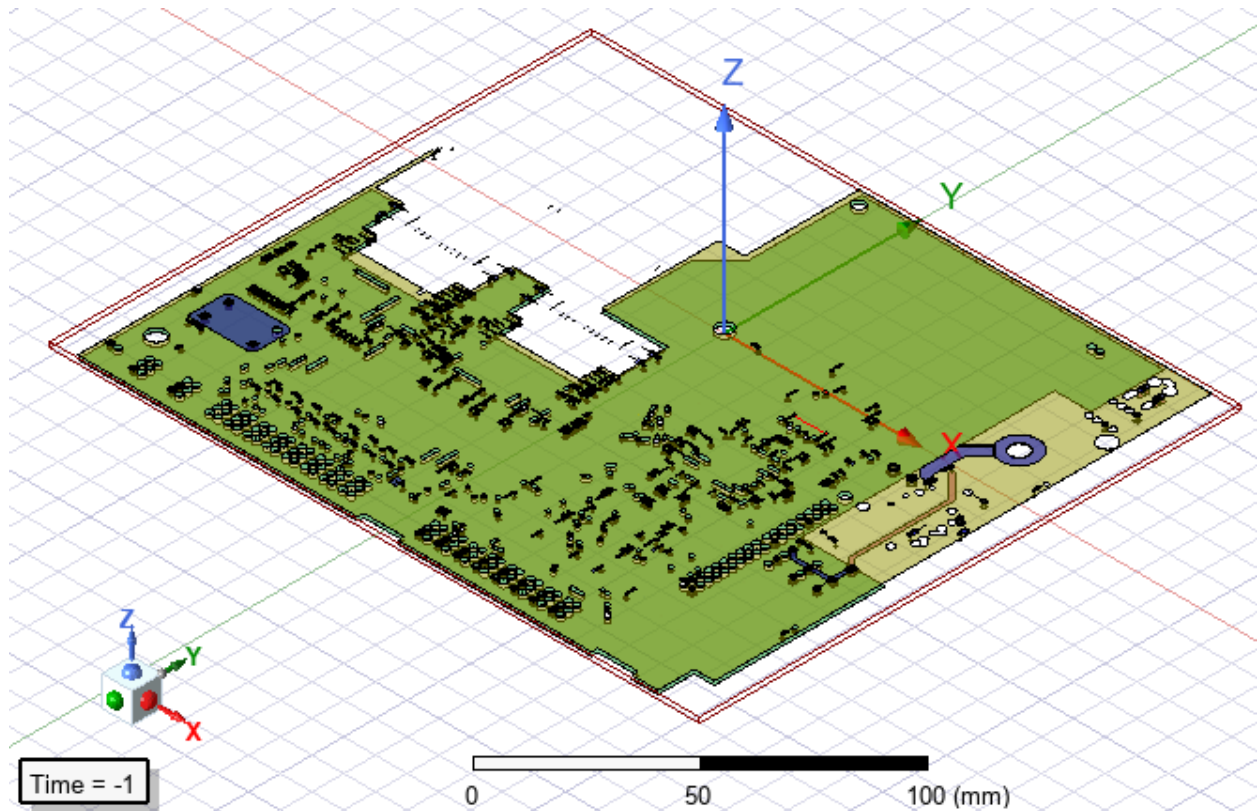

Maxwell will be used to identify the simultaneous switching noise in the device.

Goals

Your goals in *Getting Started with Maxwell: ECAD Integration with Maxwell* are as follows:

- Determine the force on the PCB due the current and voltage excitations.
- Determine the effect a permanent magnet has on the PCB

You will accomplish these goals by doing the following:

1. Import a PCB archive into HFSS 3D Layout.
2. Assign ports in 3D layout from HFSS.
3. Assign a mesh to the layout in HFSS.
4. Create a Maxwell 3D transient A-Phi design.
5. Create a region set a boundary of fringing field computation for the design and assign a flux tangential boundary condition.
6. Assign current and voltage excitations.
7. Set up and run the transient simulation, which will include a force computation and a harmonic force computation.
8. Plot the layout force, terminal current, B magnitude, J magnitude and vector results.
9. Use Maxwell's MCAD tools to add a permanent magnet to the PCB board, and rerun the simulations.

2 - Preparing a 3D Layout

In this chapter you will complete the following tasks:

- Board Import
- Port Assignment
- Solution Setup
- Mesh Operations

Import the PCB Layout

To open the PCB layout:

1. Double-click the **Ansys Electronics Desktop** icon on your desktop to launch Ansys Electronics Desktop.

You can also start Ansys Electronics Desktop by clicking **Start > All Programs > Ansys EM Suite [version] > Ansys Electronics Desktop [version]** from the Windows Start menu.

2. Click **File > Open Examples**, then,
 - a. In the Open dialog box that appears, click the parent folder icon once to move up one level above the Examples folder.
 - b. Double-click the Help folder and then the Maxwell folder.
 - c. Select the **SNN_ECAD_3DL.aedt** file.

Note: The .aedtz file is an archive file. Archive files ensure that the user has all the files needed to run a particular example.

3. Select the Project File Restore Location for the archive to be unzipped to, and click **Save**.

The archive file will be unzipped to the directory you select and then automatically opened in HFSS 3D Layout. Ansys recommends that you select a location other than the \\Help\Maxwell directory in the distribution so that you can maintain the original files as a reference.

Note: This file could have been opened directly in Maxwell, but you need to assign a mesh to the 3D layout from within HFSS 3D Layout.

4. Click **File > Save As**.

The **Save As** dialog box appears.

5. Save the file under a unique name of your choosing.

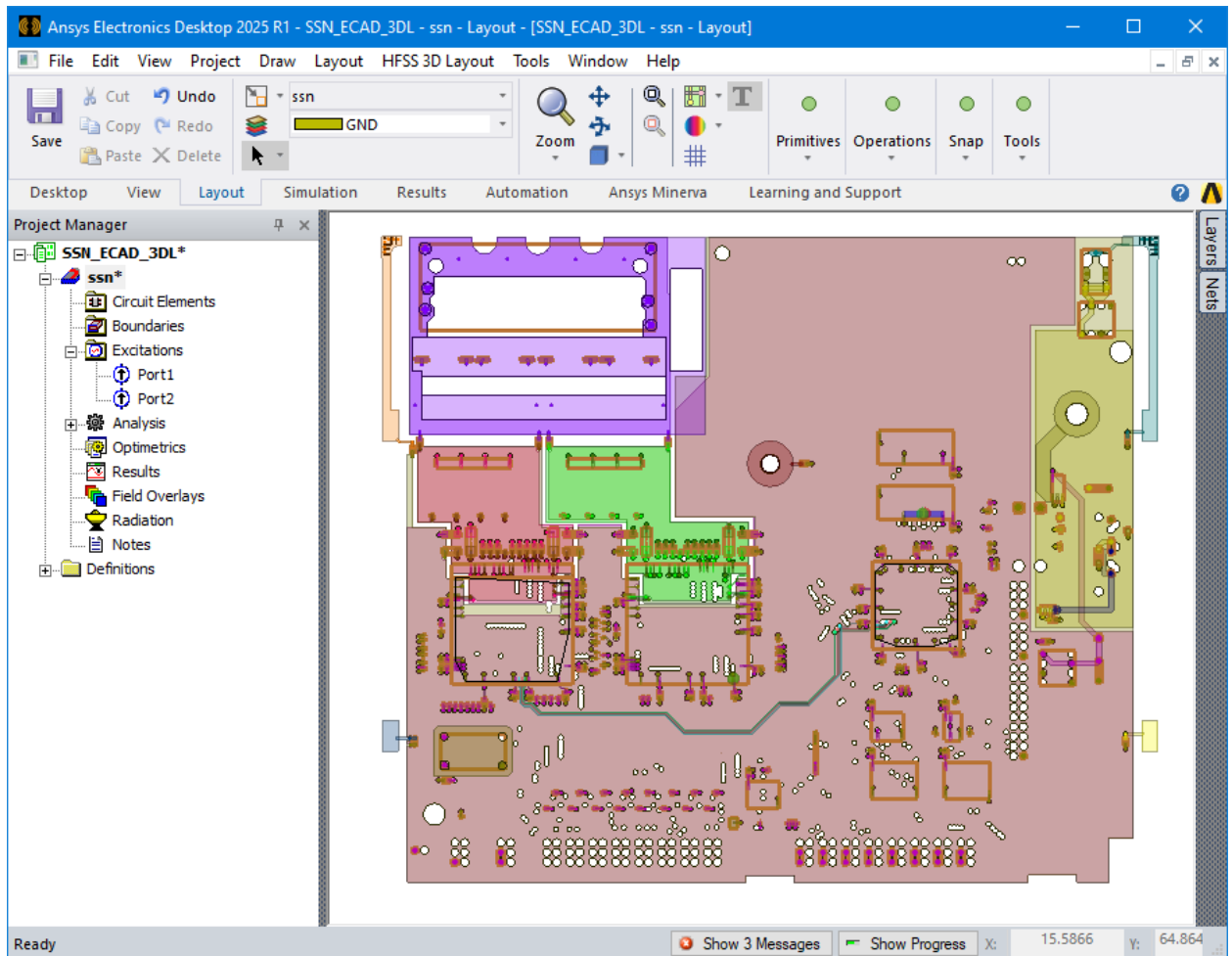

Explore Design

This design is a power delivering network with a Voltage Regulation Module (VRM) and a System on Chip (SoC).

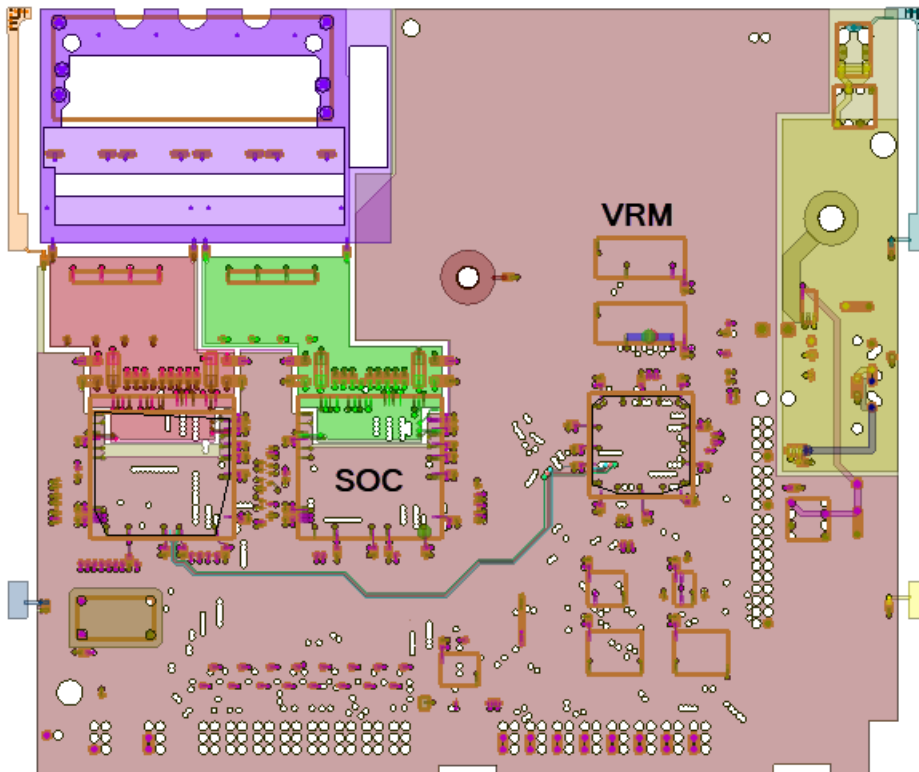

To view the layer stackup for this design, select **Layout > Layers**.

Getting Started with Maxwell®: ECAD Integration

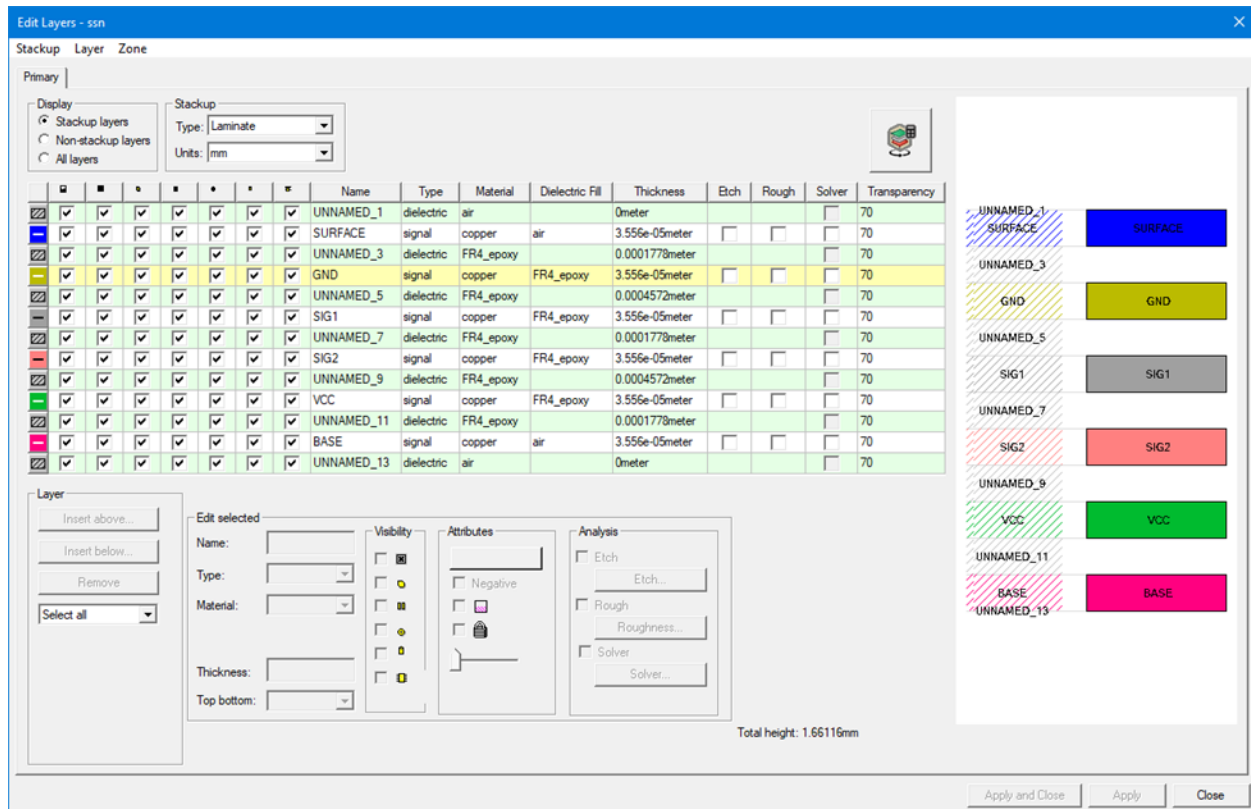

The nets of interest are GND and VCC. To view these nets:

1. From the **View** menu, make sure the **Layers** and **Nets** options are checked.

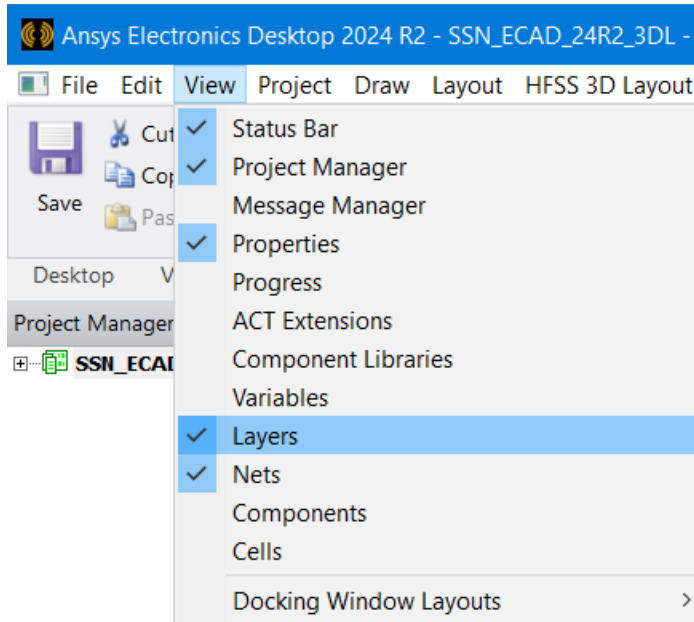

2. On the right side of the Ansys Electronic Desktop window, click on the **Layers** tab.
 - a. In the window that opens, uncheck all the layers except GND and VCC.
 - b. Uncheck all the other options except **Outline**.

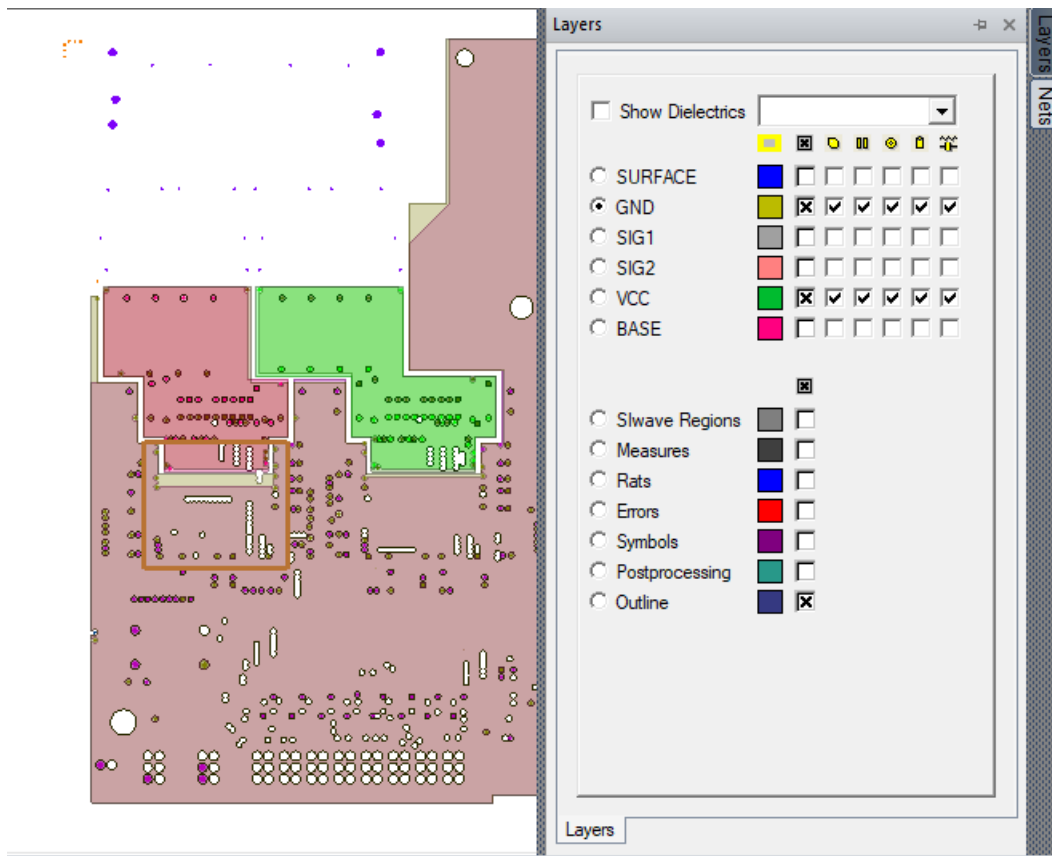

3. Click on the **Nets** tab. In the window that opens, right click on the GND net, and select **Show (Hide All Other)**.

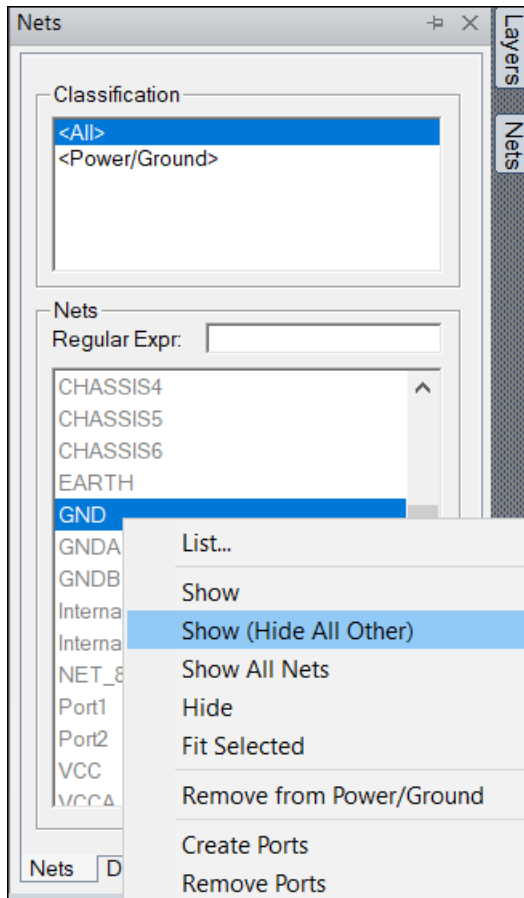

The isolated GND net is shown below. Note that it is red because it is selected in the canvas.

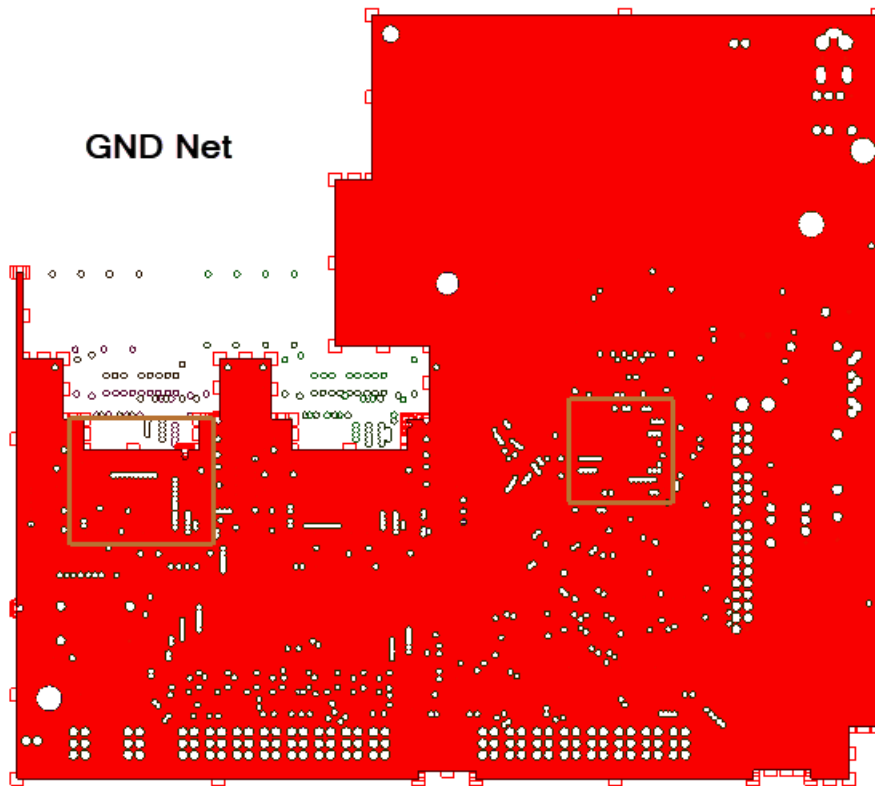

4. Reopen the Nets window, and right click on the VCC net and select **Show (Hide All Other)**.

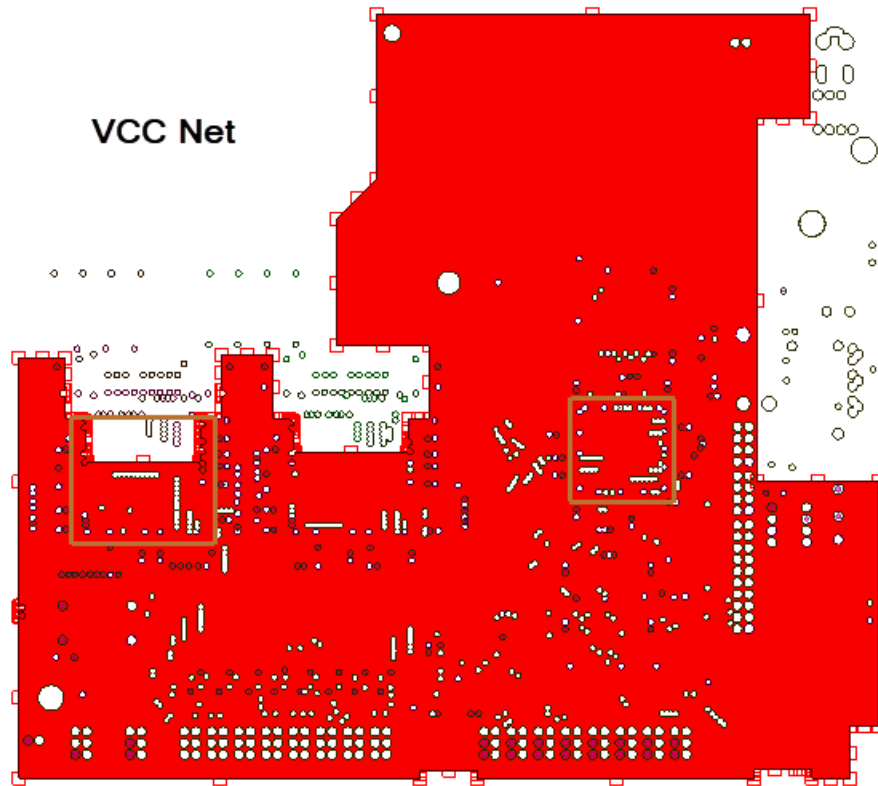

Assign Ports

Next you will select port locations. You will define ports to connect the VCC and GND nets.

1. In Nets window, use the Ctrl key to select both VCC and GND, then right click to select **Show**.

Both the GND and VCC nets are displayed in red to indicate that they are visible.

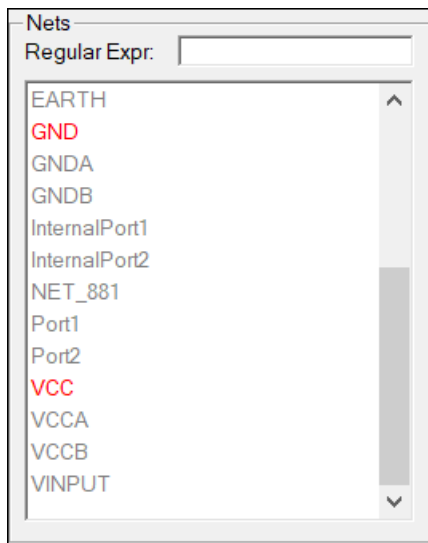

2. In the Layers window, uncheck all the layers except **Surface**, **GND**, and **VCC**.
Note that the Surface layer has the connections between the GND and VCC nets.

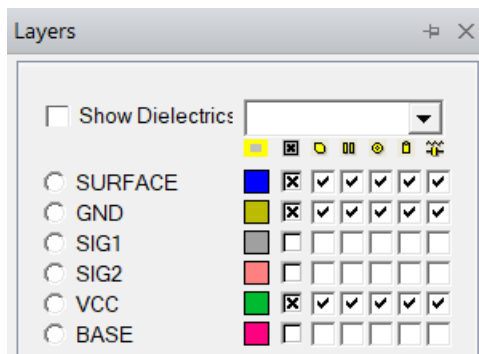

3. Color the layout by net:
 - a. Select **Layout > Settings**.
 - b. In the Design Options window that opens, check the **Color by net**.

VCC pins are in magenta, and GND pins are in green:

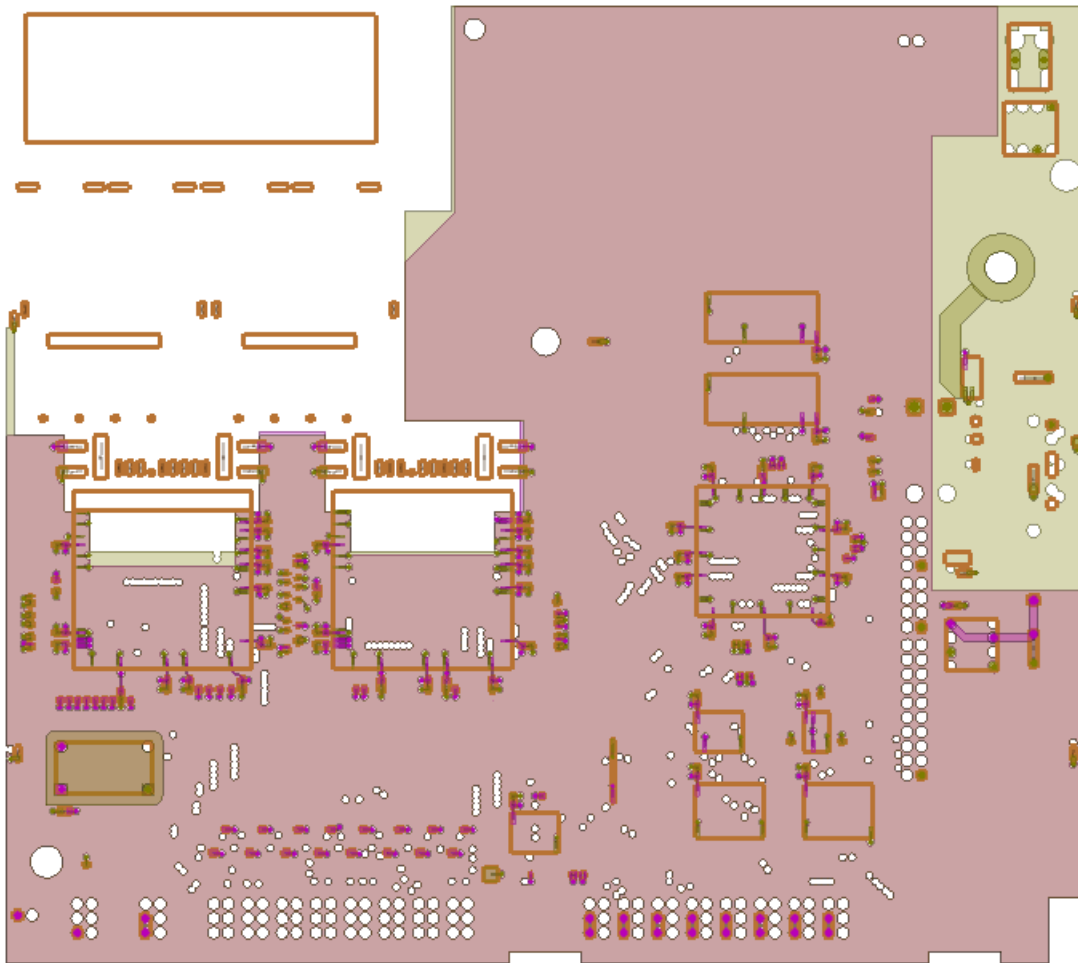

Port1 will be assigned on SoC, and Port2 will be assigned on VRM, as shown below:

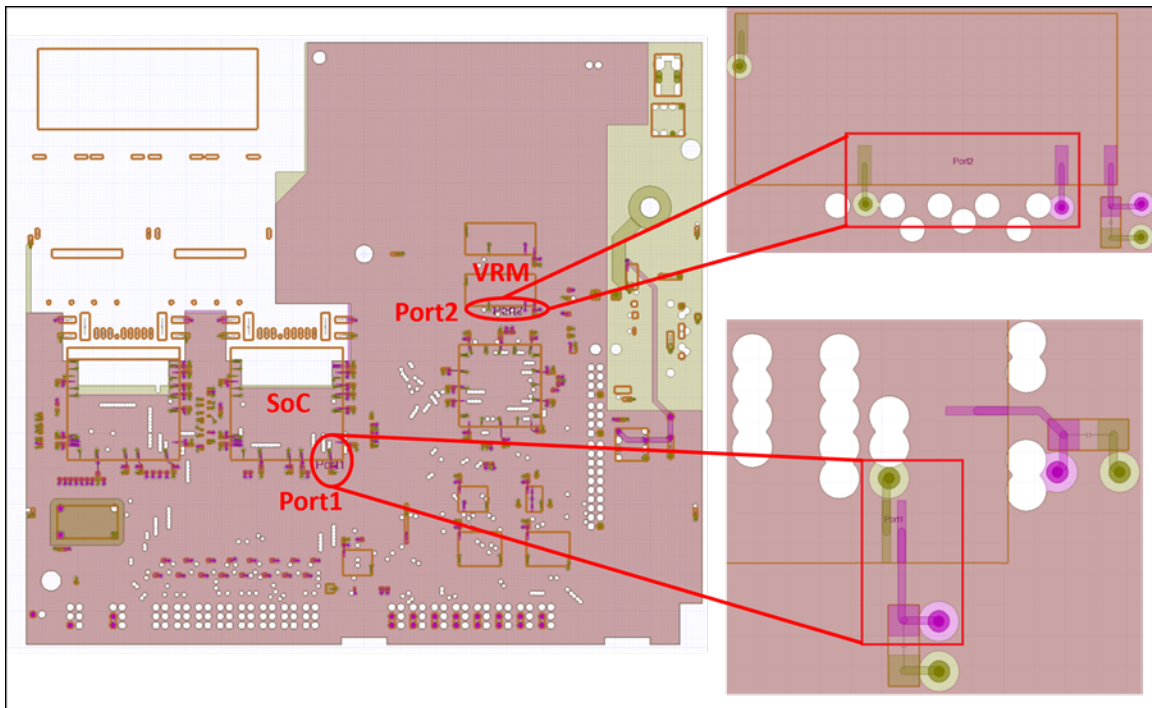

4. Use the **Select** icon with the **Ctrl** key to select both VCC and GND pins that will define Port1.

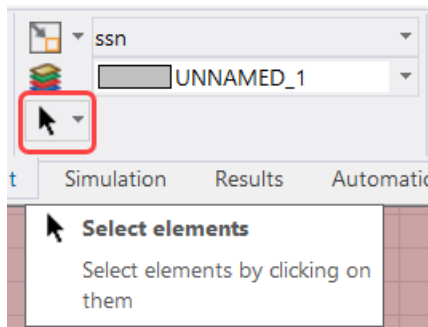

5. Right-click and select **Port > Create Circuit Ports**.

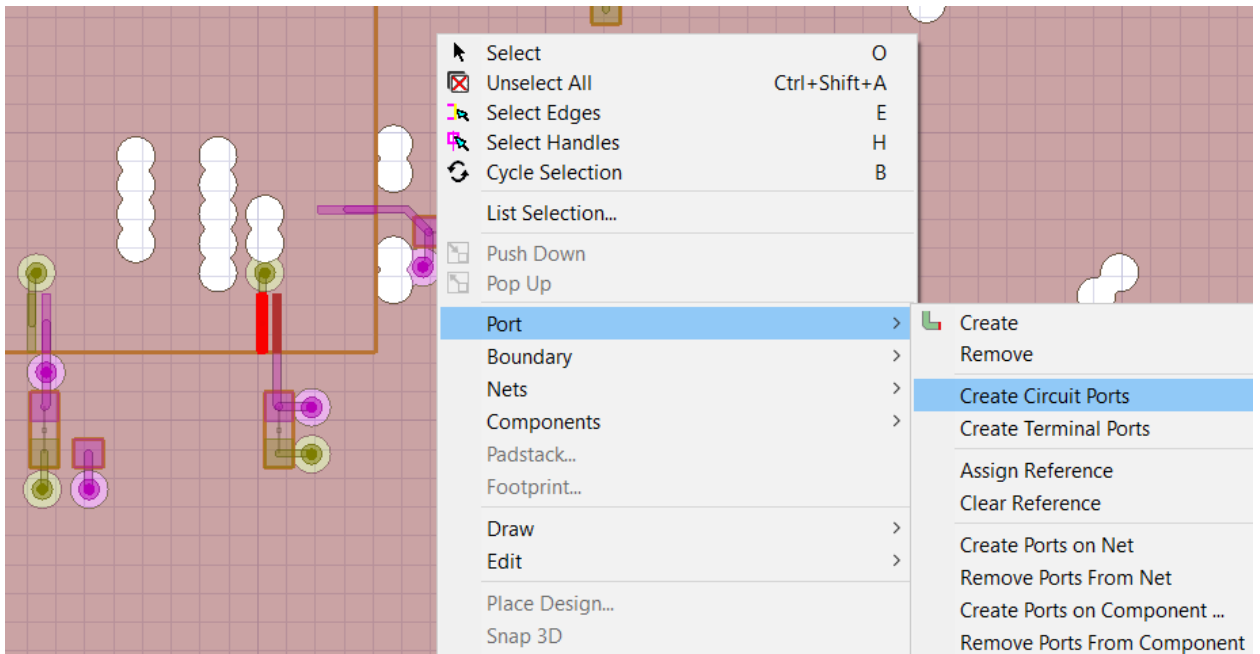

6. Repeat the above step for Port2 assignment.
7. In the Project Manager tree, expand the **Excitations** entry. The ports you created are listed.
8. Right-click on the first port and select **Rename**. Name it **Port1**.
9. Rename the other port **Port2**.

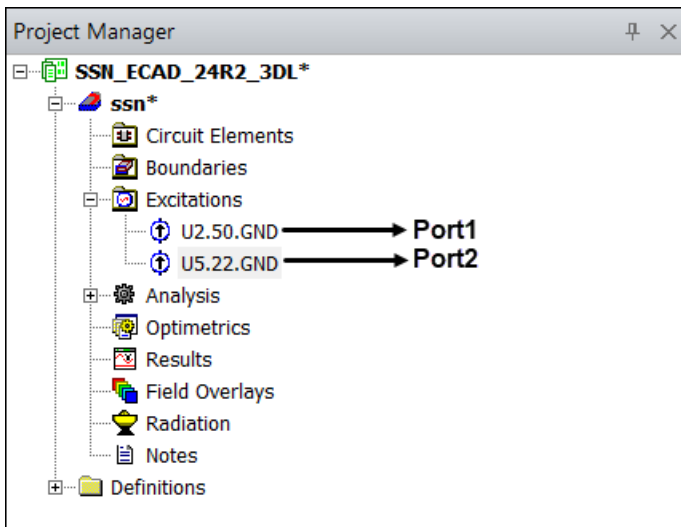

Set Up Solution

1. In the Project Manager tree, right-click on the **Analysis** entry, and select **Add HFSS Solution Setup > Advanced**.

The **Setup** dialog box appears.

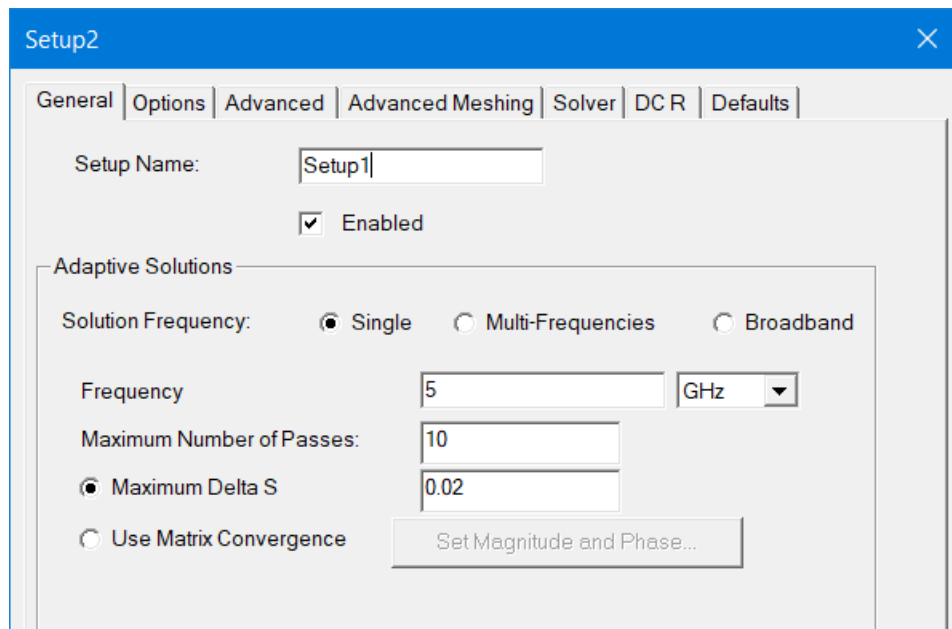

2. The default settings are sufficient, so click **OK**.
3. View the default settings in the Edit Frequency Sweep dialog box that opens, then click

OK.

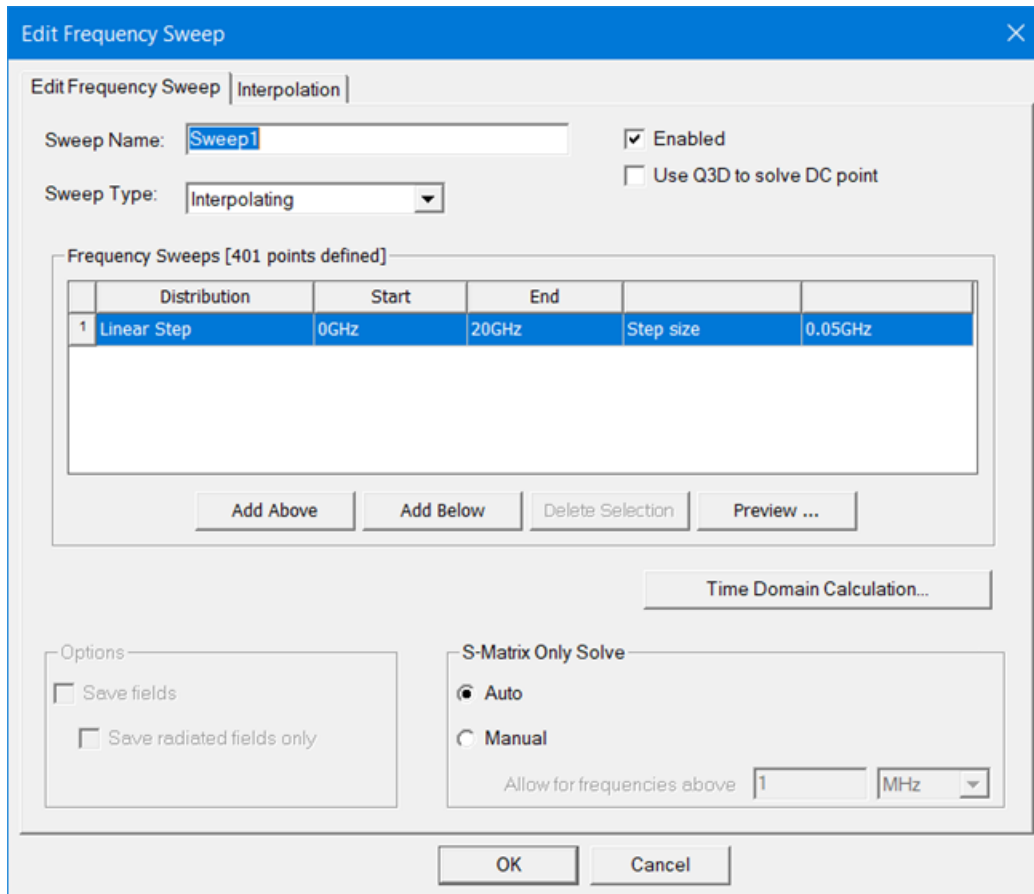

Assign a Mesh Operation

In this section, you will assign a mesh to the layout. For ECAD components, the meshing must be done in HFSS 3D Layout. After the layout is imported into Maxwell, you will further modify the device to use the Phi mesh, but the initial mesh must be done here.

1. Make sure that only VCC and GND are still selected in the Nets window.

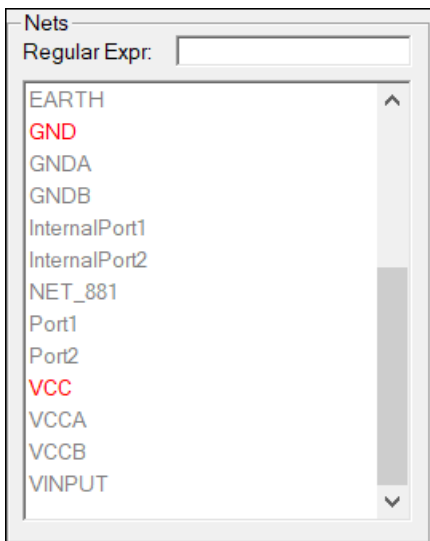

2. In the Project Manager tree, right-click on Analysis\Setup1, and select **Assign Mesh Operation > Inside Selection > Length Based**.

Note: Length-based mesh operations inside volumes can be applied to non-model box primitives; the imported layout is considered a [non-model](#).

3. In the Select Geometry dialog box that opens, do the following:
 - a. Select the layers for the GND and VCC nets as shown below.
 - b. Check **Restrict Length**, and set **Max. Length** for 10 mm.
 - c. Click **OK**.

Note: When you request length-based mesh refinement, you instruct Maxwell to refine the length of tetrahedral elements until they are below the Max Length value. The length of a tetrahedron is defined as the length of its longest edge. Maxwell refines the element edges inside the object until they are equal to or less than this value. The default value is set to 20% of the maximum edge lengths of the bounding boxes of each selected object's faces.

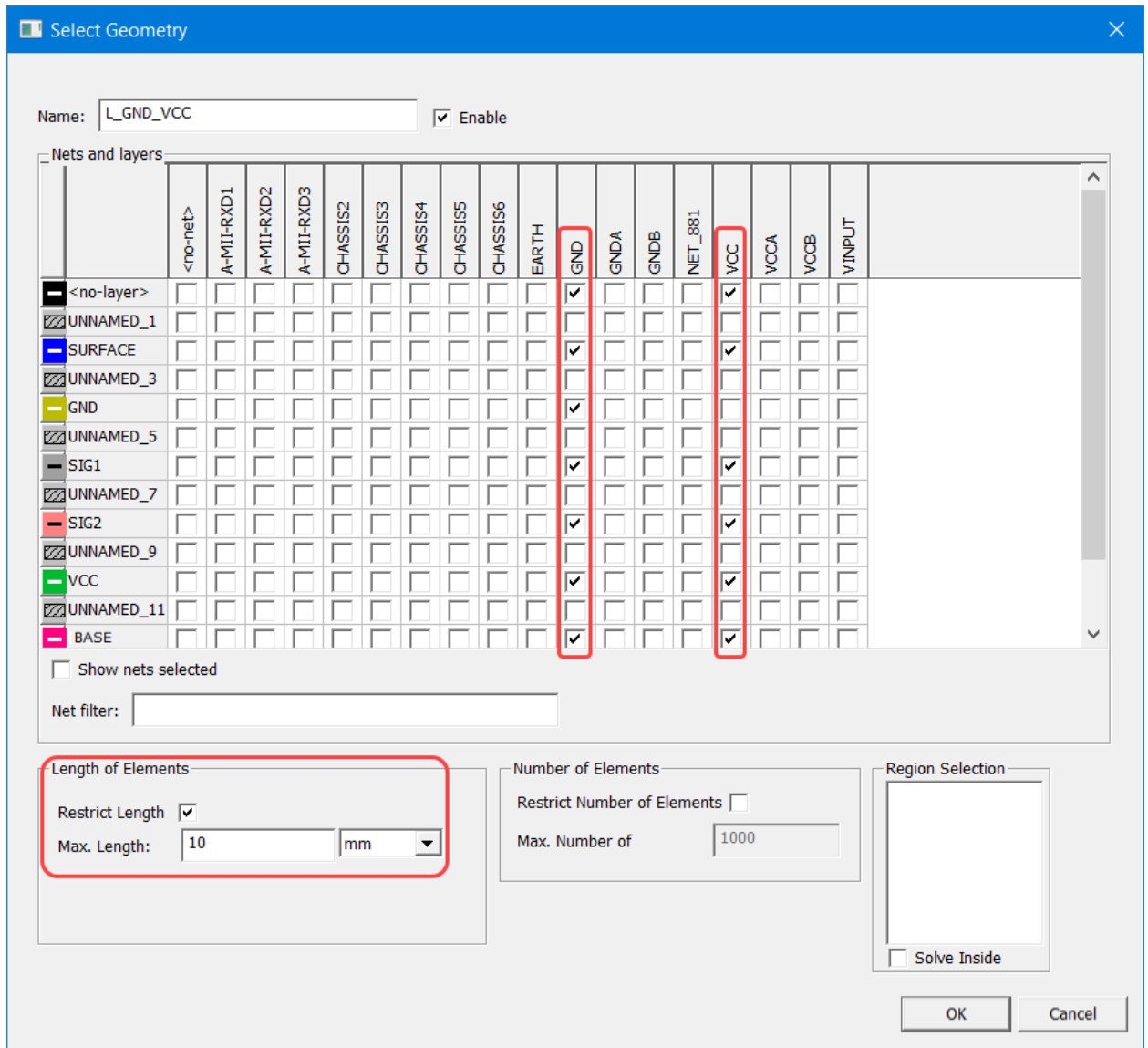

4. Right-click on **Analysis\ Setup1** and select **Generate Mesh**.

Note: The meshing operation may take several minutes. You can monitor the progress in the Progress pane.

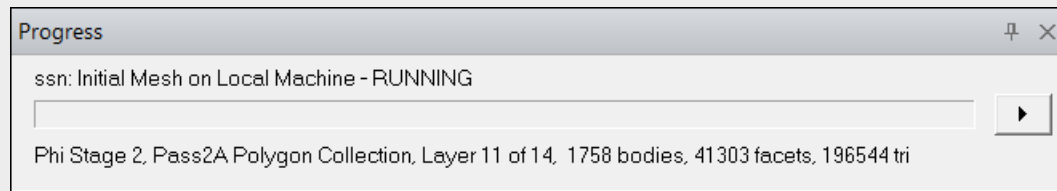

5. View the mesh created on GND:
 - a. In the Project Manager tree, right click on the **Field Overlays** entry, and select **Plot Mesh**.
 - b. In the dialog box that opens, for the GND net, select **<no-layer>**, **SURFACE**, **GND**, and **Base**, then click on **Done**.
 - c. To make the GND mesh more visible, open the **Layers** tab, and unselect all the layers except **GND**.

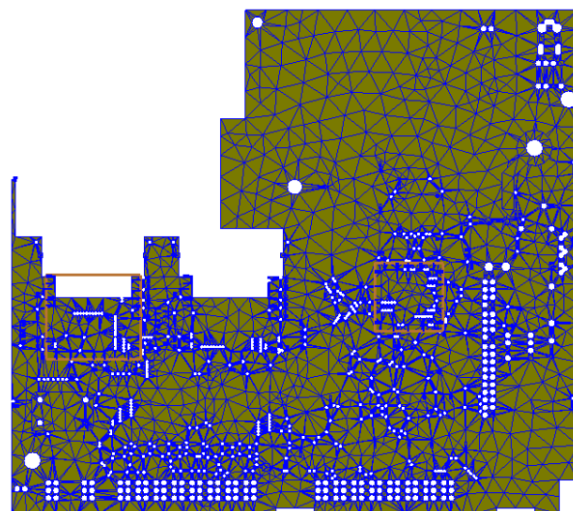
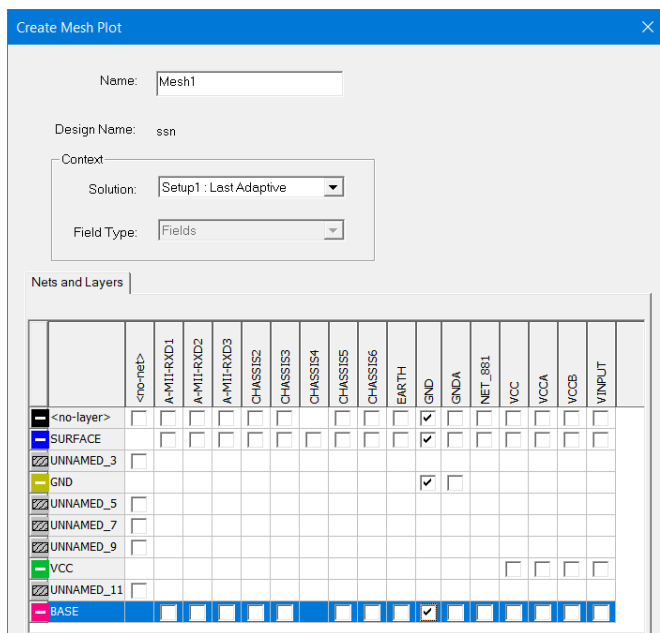

6. View the mesh created on VCC:
 - a. In the Project Manager tree, right click on the **Field Overlays** entry, and select **Plot Mesh**.

- b. In the dialog box that opens, for the VCC net, select **<no-layer>**, **SURFACE**, **VCC**, and **Base**, then click on **Done**.
- c. To see the VCC mesh, in the Project Manager's tree, expand **Field Overlays > Mesh Plots**, then right click on **Mesh1** and uncheck **Plot Visibility**.
- d. To make the VCC mesh more visible, open the **Layers** tab, and unselect all the layers except **VCC**.

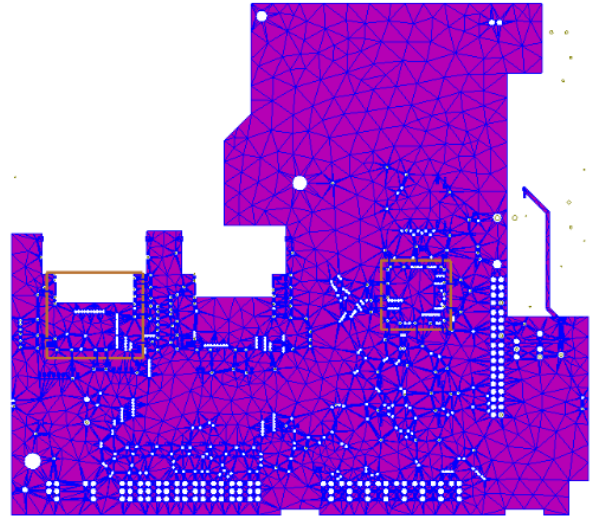
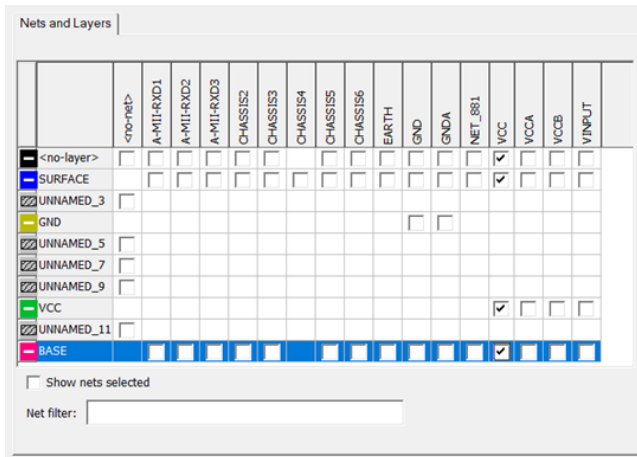

3 - Create the Maxwell 3D A-Phi Transient Design

If you would like, you can create a new project to create the Maxwell design or you can create another design inside the existing project. The procedure for importing the 3D layout is the same.

1. Click **Desktop** tab.
2. From the Maxwell drop-down list, select **Maxwell 3D**.
3. In the Project Manager tree, right-click on the Maxwell3DDesign entry, and select **Solution Type**.
4. In dialog box that opens, select **Transient**, and check the **A-Phi Formulation**.

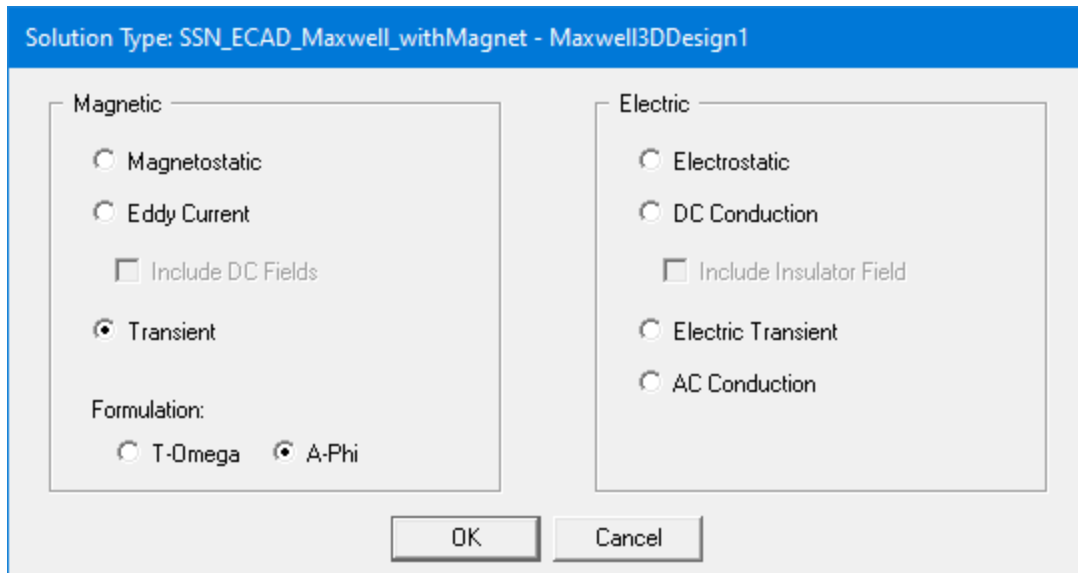

5. Click **OK**.

Note: The A-Phi Formulation solver solves second-order Φ for the electrical field, and solves first-order A for magnetic field. (In order to account the difference in the order of elements solved, increasing the mesh density in A-Phi should help achieve the same B field results as T-Omega.)

The A-Phi solver supports multi-terminals with mixed excitation types on the same conduction path, and it is computationally efficient and flexible for ECAD PCB and other electronics applications.

Import 3D Layout to Maxwell

1. Expand the **Maxwell3DDesign** entry in the Project Manager tree, right-click on **3D Components** and select **Browse Layout Component > Browse to Project aedb Folder**.

Note: The **Browse Layout Component** option is only available with the [Transient A-Phi Formulation](#).

2. In the Browse window:
 - a. Navigate to the directory where you have your project.
 - b. *Double click* on the **SSN_ECAD_3DL.aedb** directory.
 - c. Select **Open**.

Note: An imported 3D layout file can only contain one design; if there are multiple designs in the layout, the import will fail.

3. In the Insert Layout Component window, click on the **Coordinate System** tab, and select the Global coordinate system as the **Reference**.

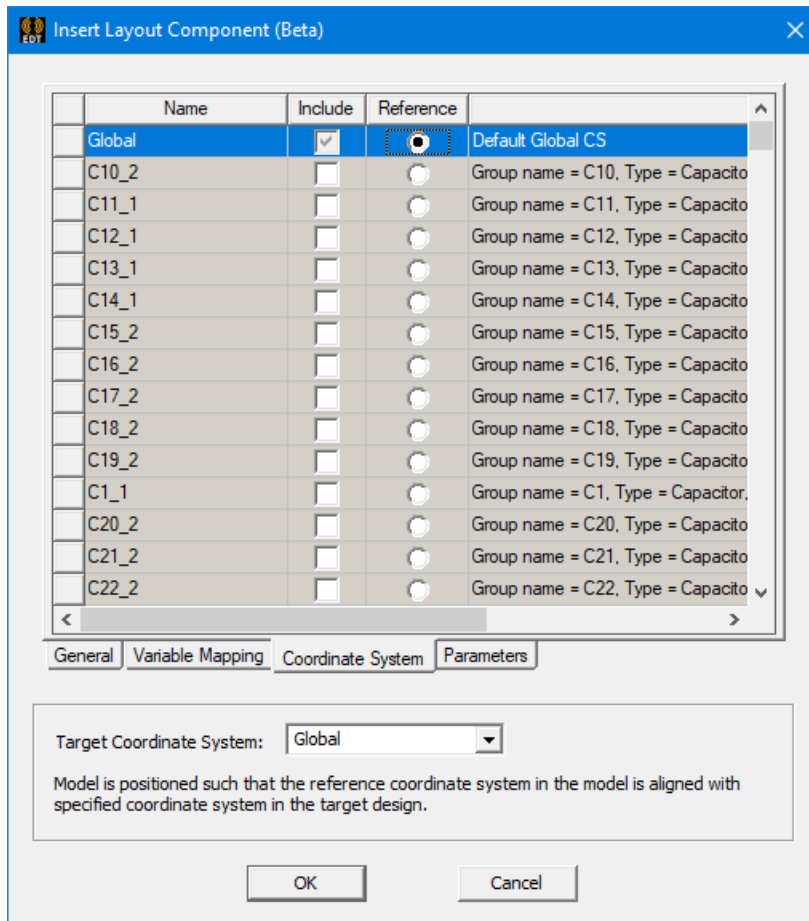

4. Click **OK**.

The imported PCB is shown below:

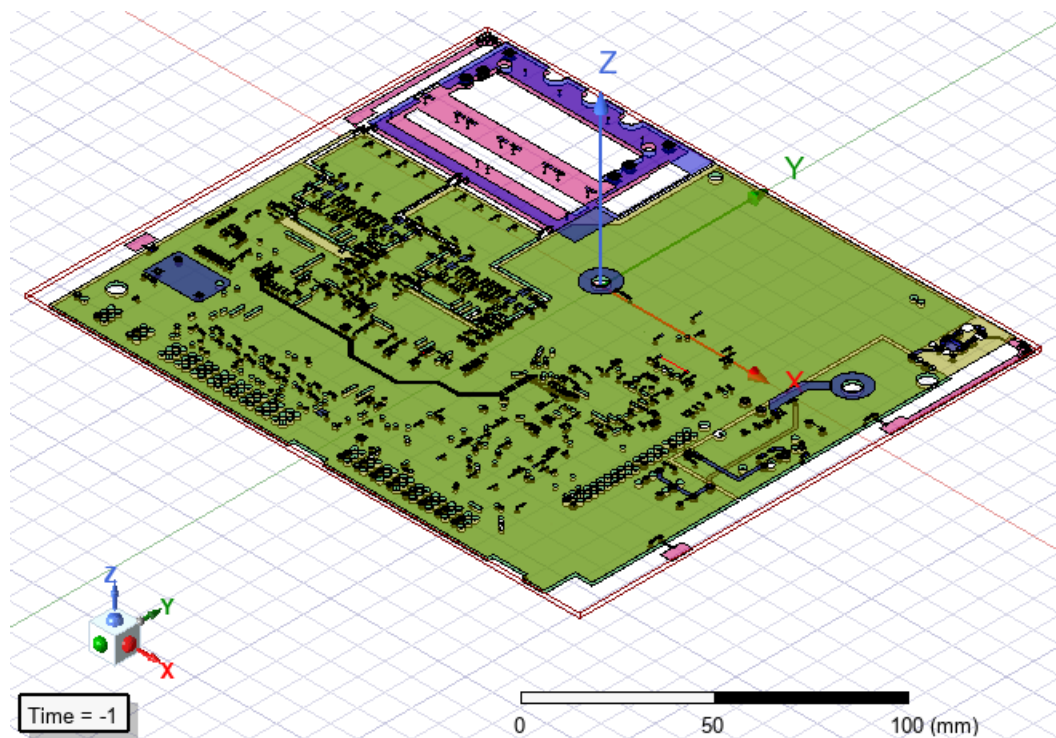

5. Modify 3D Layout Component Visualization so that only VCC and GND are shown:
 - a. In the model history tree, right-click on **LC1_1**, and select **Properties**.
 - b. Click on the **Visualization** tab.
 - c. Click on the **Object Attributes** button.
 - d. For Display Model, select **Net**.
 - e. Uncheck all nets except **VCC** and **GND**: Click on the Show label in the Column to uncheck all the nets, and then select **VCC** and **GND**.
 - f. Uncheck **Show Dielectric**.
 - g. Click **Apply** and **OK** in the Object Attributes window.
 - h. Click **OK** in the Properties window.

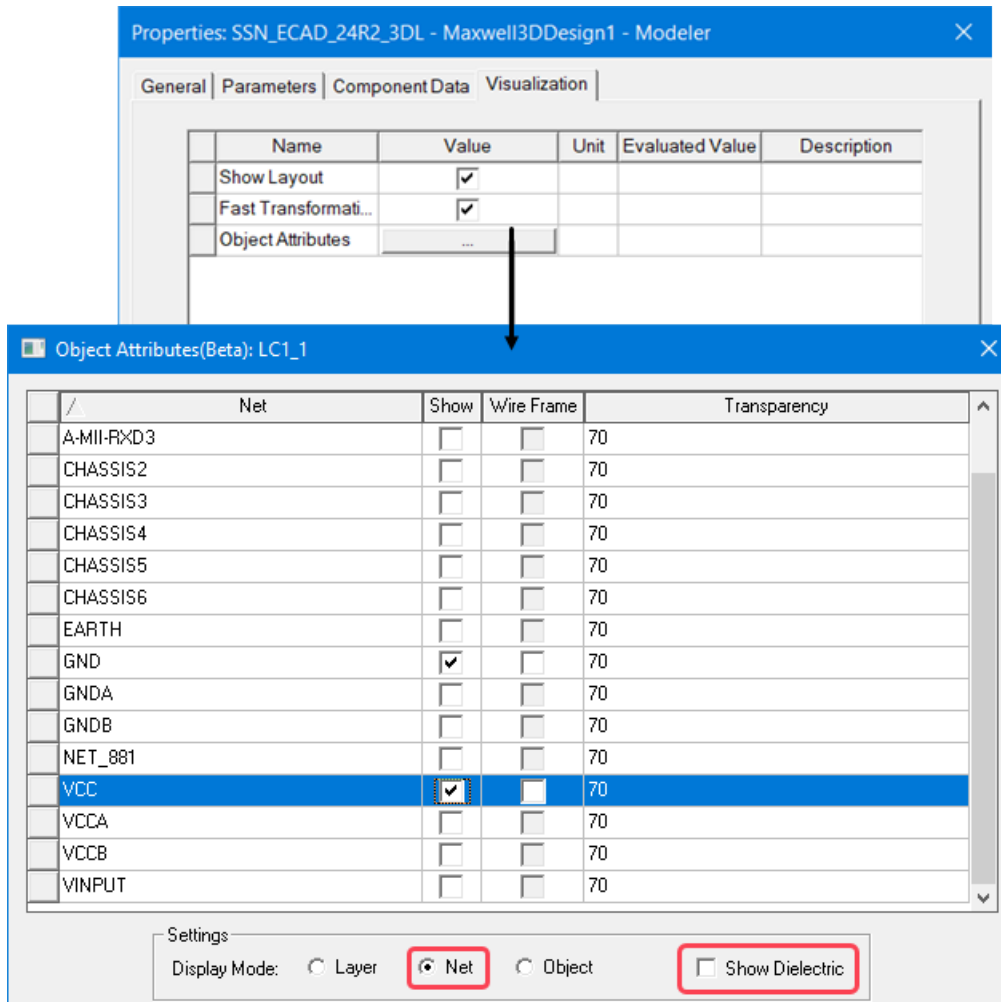

The modified view is shown below:

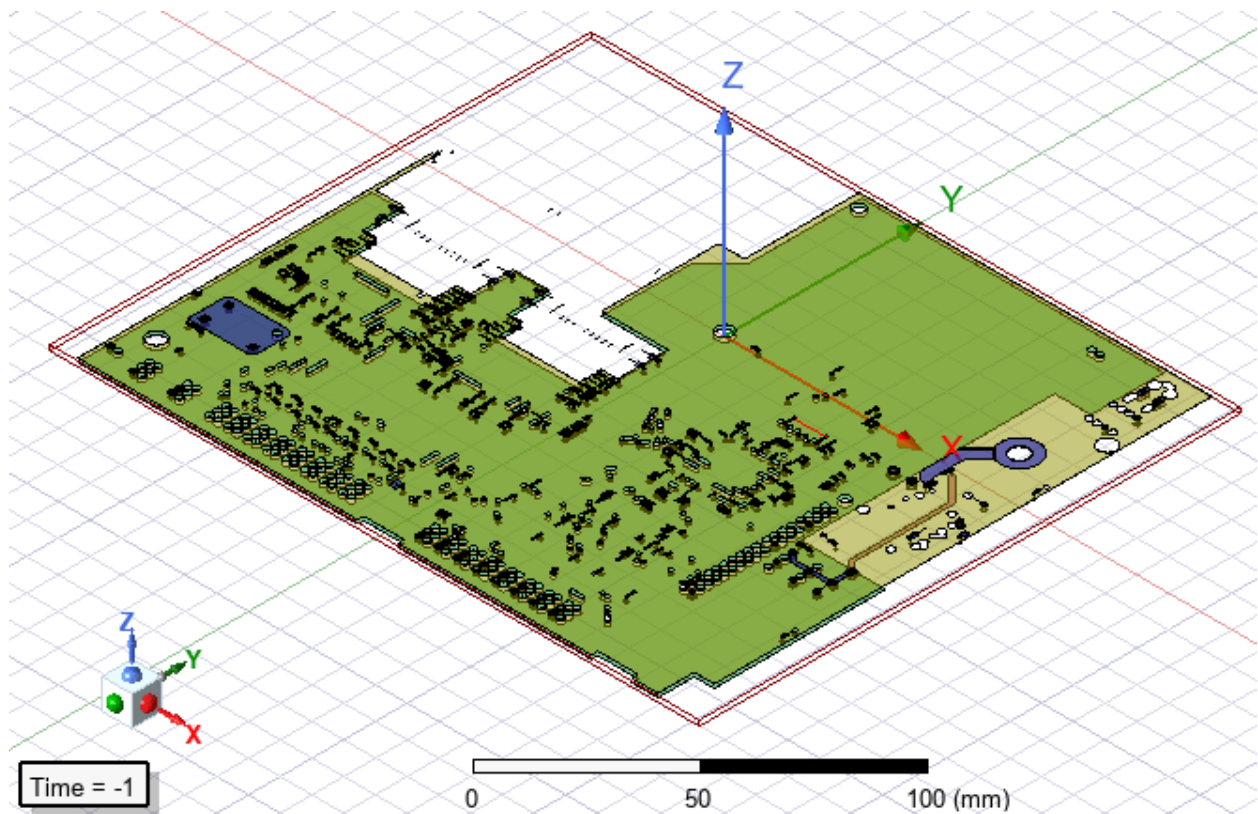

Note: If you get an **Import Failed** error when you import a 3D Layout, it may be because there is more than one design in the layout. Make sure there is only one design in the 3D Layout file before importing into Maxwell.

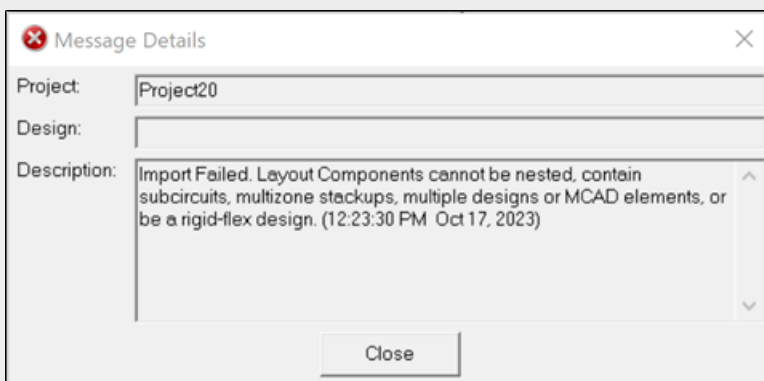

Modify an Imported Layout

After a 3D layout component has been imported into Maxwell, it can be edited:

Right click on the 3D layout component in the Project Manager tree, and select **Edit Definition**. The layout will be opened in the Maxwell project for editing.

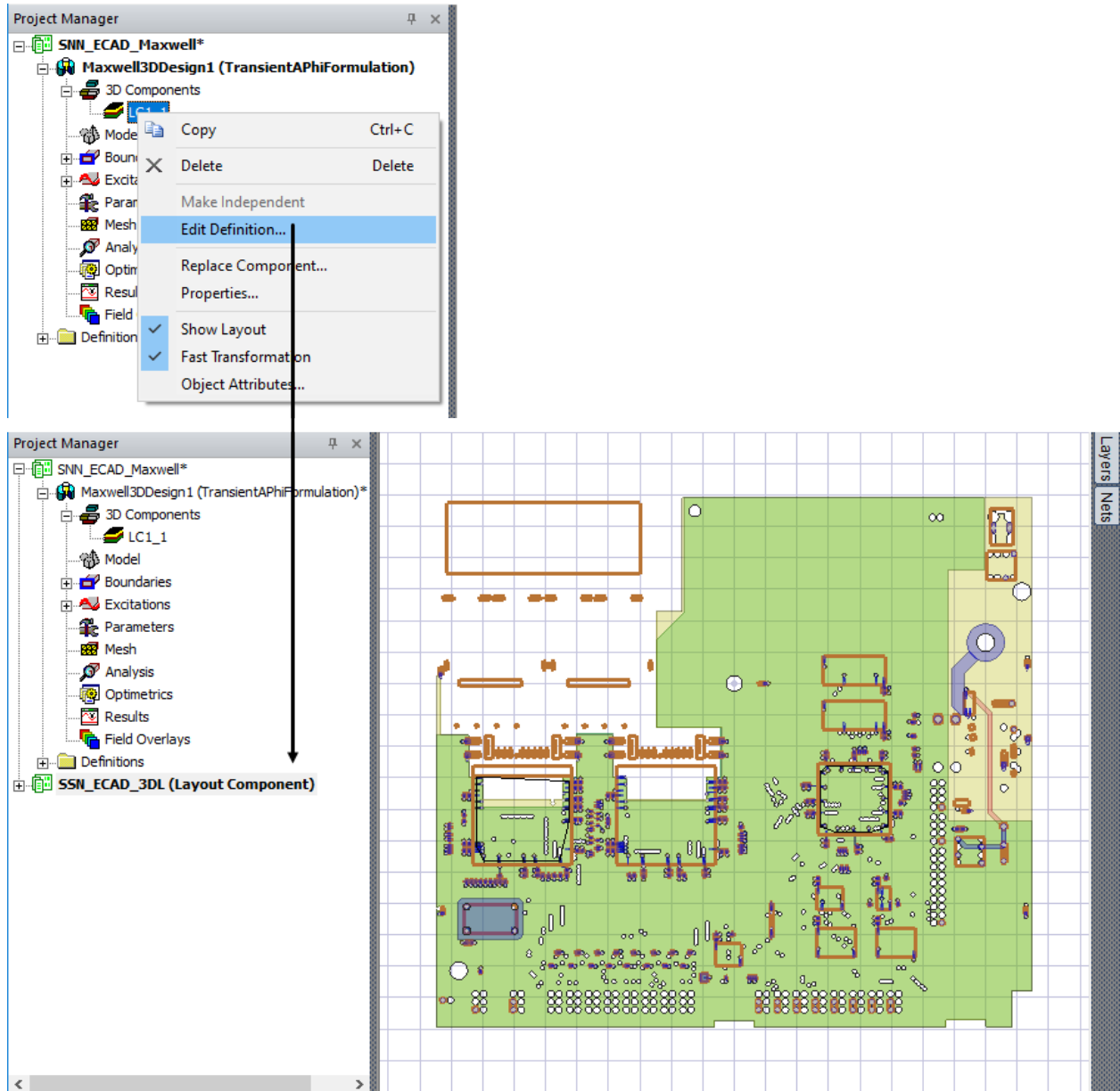

When you save the 3D Layout design, the modifications will be updated in the Maxwell design. You may have to modify the 3D Layout component visualization in Maxwell to make sure components are shown correctly; see [Import 3D Layout to Maxwell](#) for details.

Create Simulation Region

In these next steps you will create a region and apply a flux tangential boundary condition to it. The region sets a boundary for the fringing field computation; the field is only calculated with that region.

1. From the **Draw** menu, select **Region**.
2. Select **Pad individual directions**.
3. For the +X, -X, +Y, -Y directions, enter a value of 100. For the +Z and -Z directions, enter a value of 600.
4. Click **OK**.

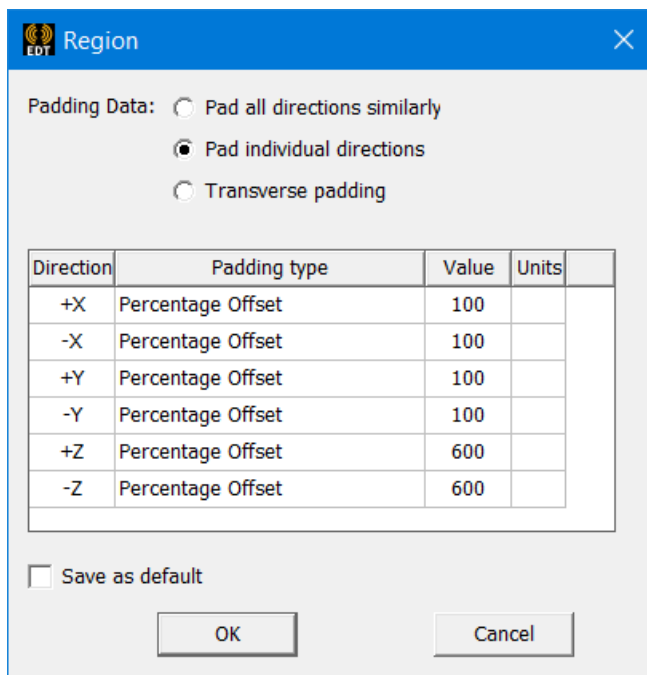

Note: The required size of the region will vary according to the device, but a general rule is that it should be four to five times larger than the geometry of the device.

5. Select the Region in the **3D Modeler window**, then right-click and select **Extend Selection > All Object Faces**.

- Right-click on the Region again and select **Assign Boundary > Flux Tangential**, then click **OK** to apply and close the dialog box.

A **FluxTangential** boundary condition is now listed in the **Boundaries** folder.

Note: For an ECAD workflow using A-Phi solver, the boundary must be set to **Flux Tangential**, which defines H as tangential to the boundary and flux cannot cross it.

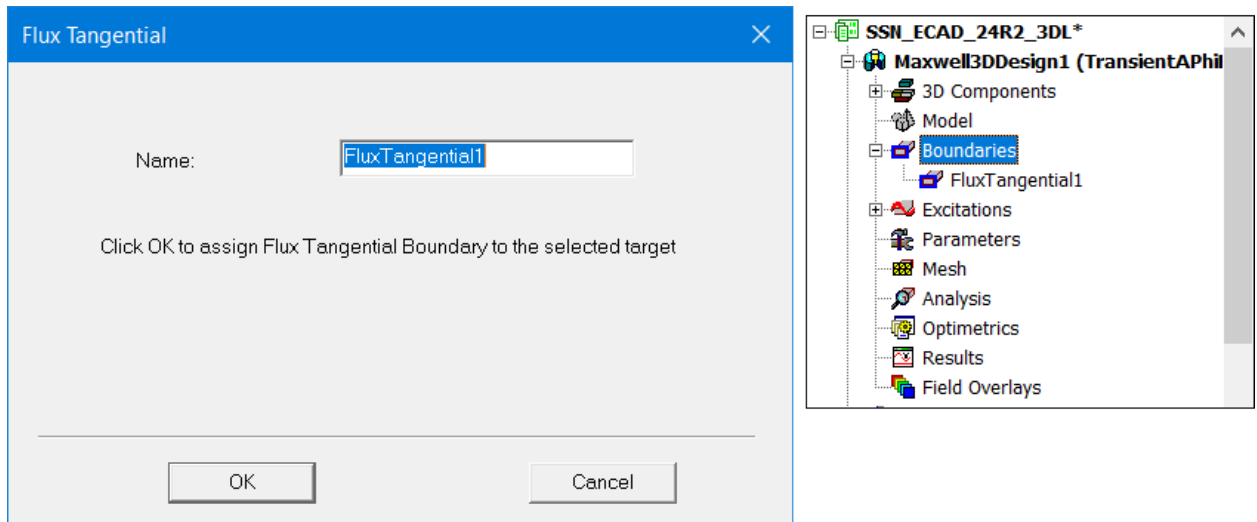

Assign Excitation

When the 3D Layout Component is imported in Maxwell 3D A-Phi Transient solver, the ports assigned in 3D Layout are automatically mapped into Maxwell as **excitations**. Users can modify the excitation source type and excitation value for each assigned port.

- In the Project Manager tree, expand the **Excitations** folder, and double click on **LC1_1_Port1** to open its properties.
- In the Properties window that opens:
 - Set the Excitation Type to **Current**.

Note: If the row that was labeled **Voltage** does not change to **Current**, click **OK** in the Properties window, then reopen.

- b. Assign $10 \cdot \sin(2 \cdot \pi \cdot 10000 \cdot \text{Time})$ for the current value.
- c. Set the unit to A.
- d. Optional: When the 3D layout was imported into Maxwell, the ports are interpreted as floating. This boundary condition will generate correct results, but if you would like to plot potential, set Negative Terminal to **Ideal Ground**.
- e. Click **OK**.

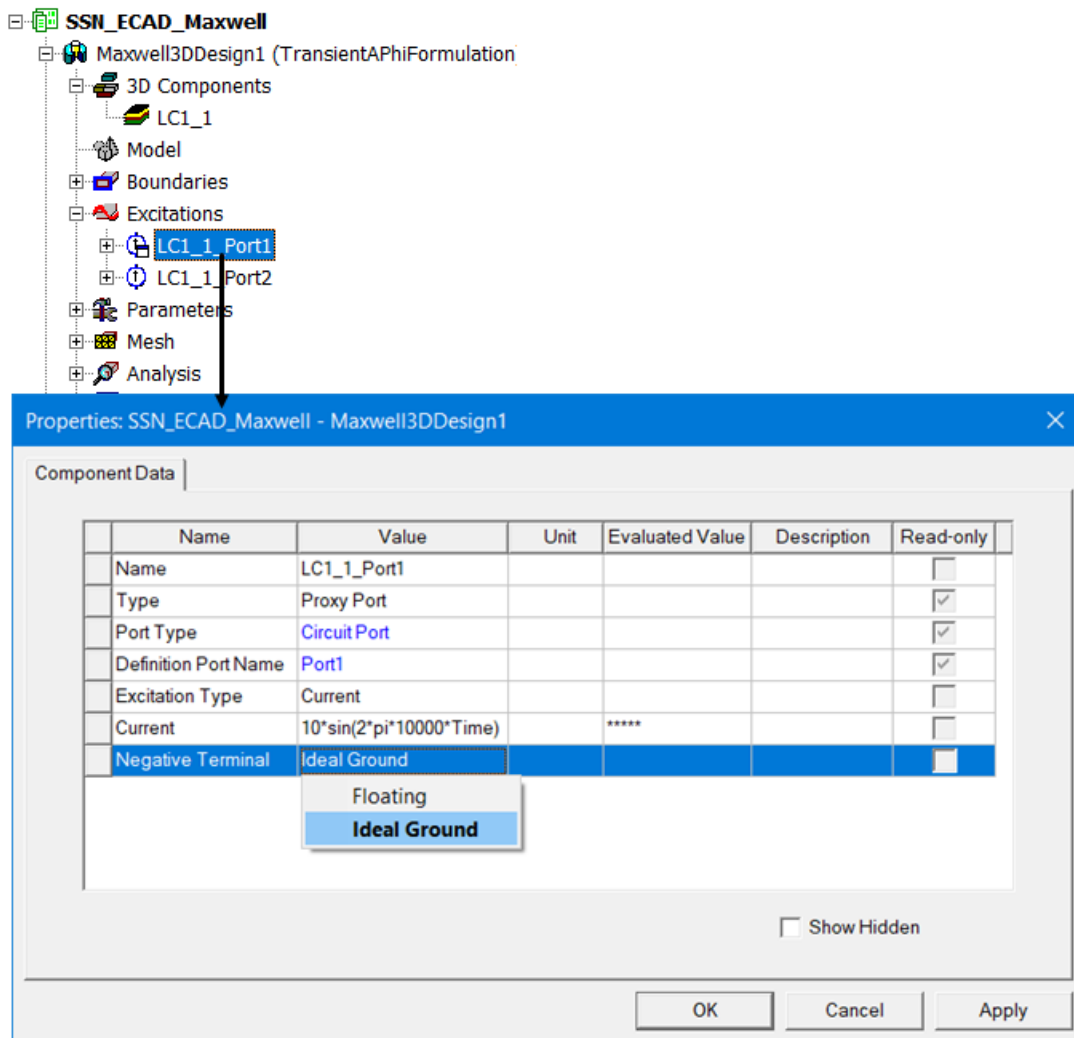

3. Assign a 0 V excitation to Port2.
 - a. Double click on **LC1_1_Port2** in the Excitations folder.
 - b. For the Excitation Type, select **Voltage**.
 - c. Assign 0 V for the voltage value.

d. Click **OK**.

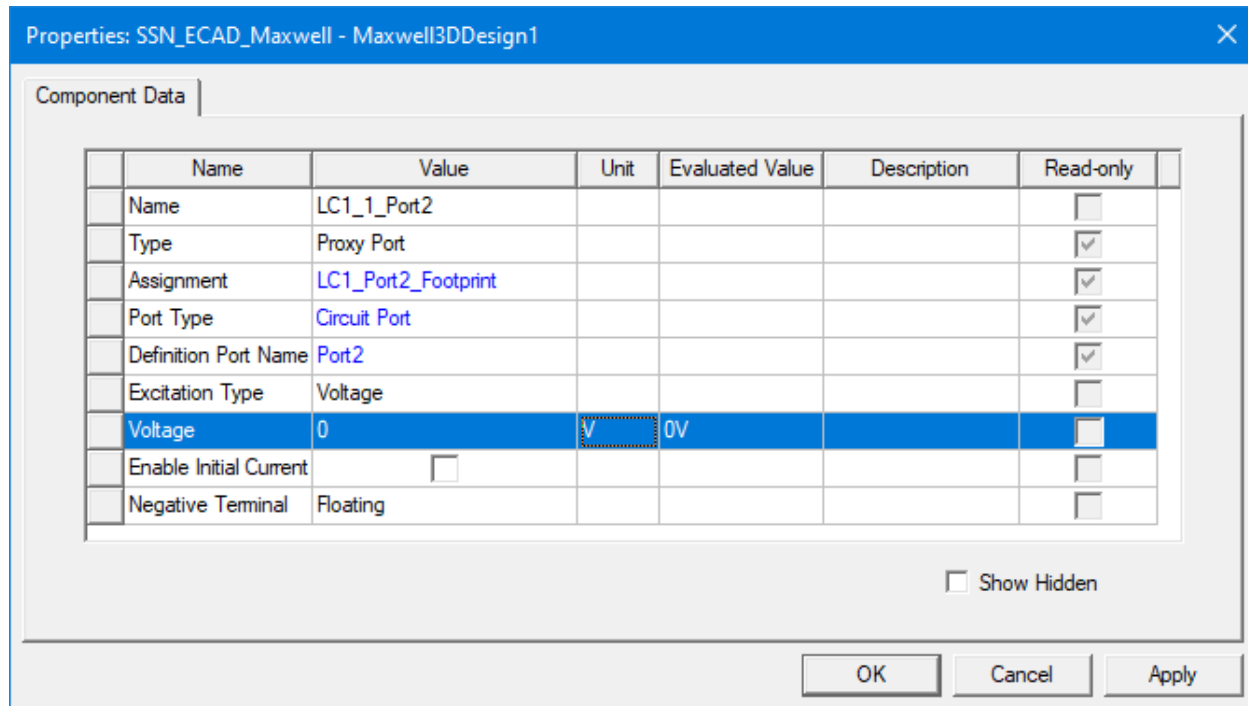

Specify Initial Mesh for Maxwell

1. In the Project Manager tree, right-click on **Mesh**, and select **Initial Mesh Settings**.
2. For the Mesh Method, select **Classic**.

Note: Although a mesh was assigned to the device in the HFSS 3D Layout, we want to further modify the mesh to use the Classic\Phi mesher, which is an advanced layout-based meshing technology that can produce meshes rapidly and generate fast and accurate results. It is used for planar structures.

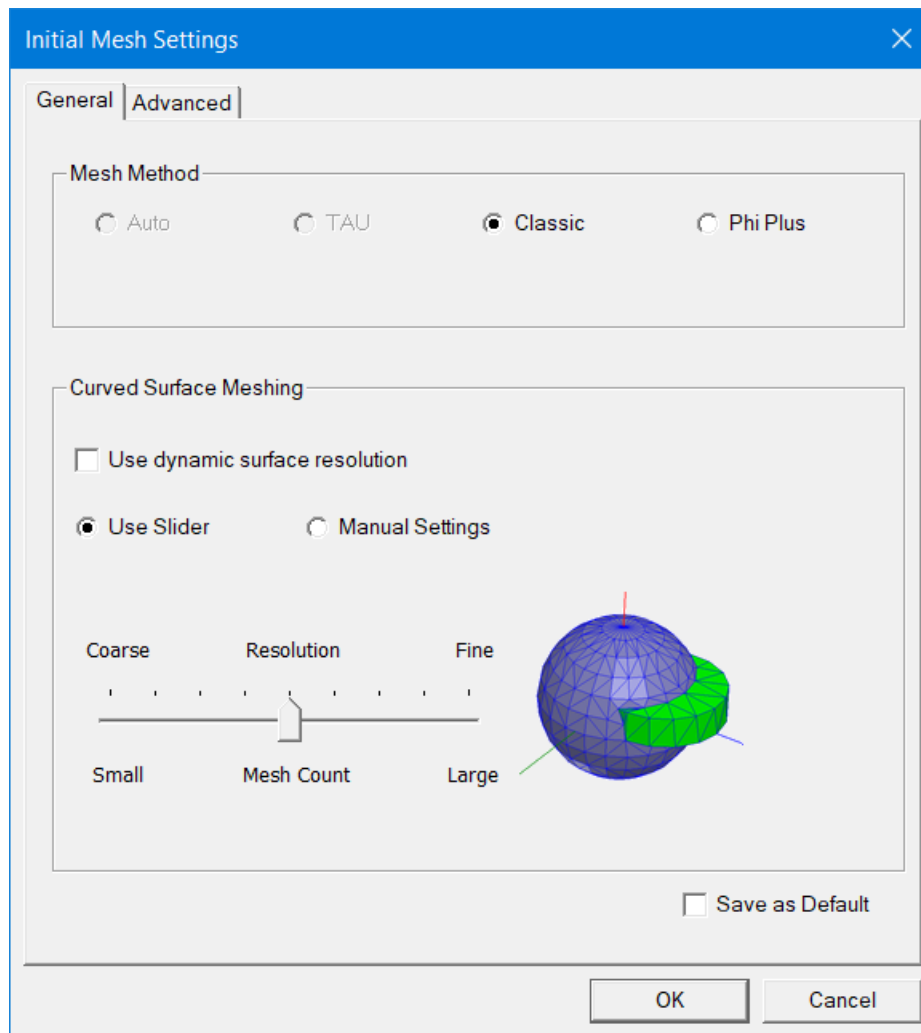

3. Click on the **Advanced** tab.
4. Check the **Allow Phi for layered geometry (Classic only)** option.
5. Click **OK**.

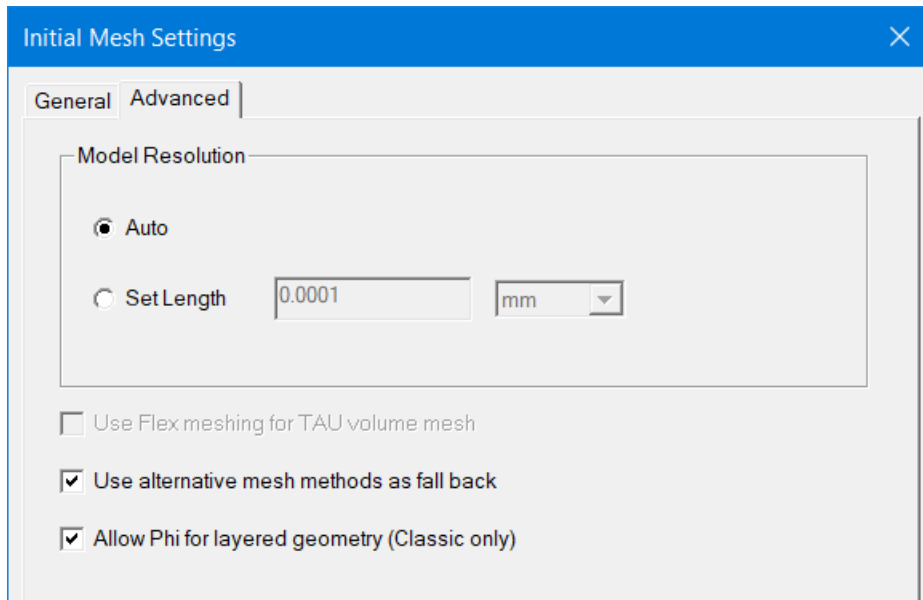

4 - Generating a Solution

Now you are ready to specify solution parameters and generate a solution for the PCB model. You will do the following:

- Set the [simulation criteria](#) that determines how Maxwell 3D computes the solution.
- Set up [force parameters for layout computation](#)
- Set up a [harmonic force calculation](#)
- [Validate your design](#)
- [Run the simulation](#)

Add Solution Setup

Next, you will add a solution setup to define the simulation time from 0-200 μs in steps of 3.33 μs .

1. In the Project Manager tree, right-click **Analysis** and select **Add Solution Setup**.

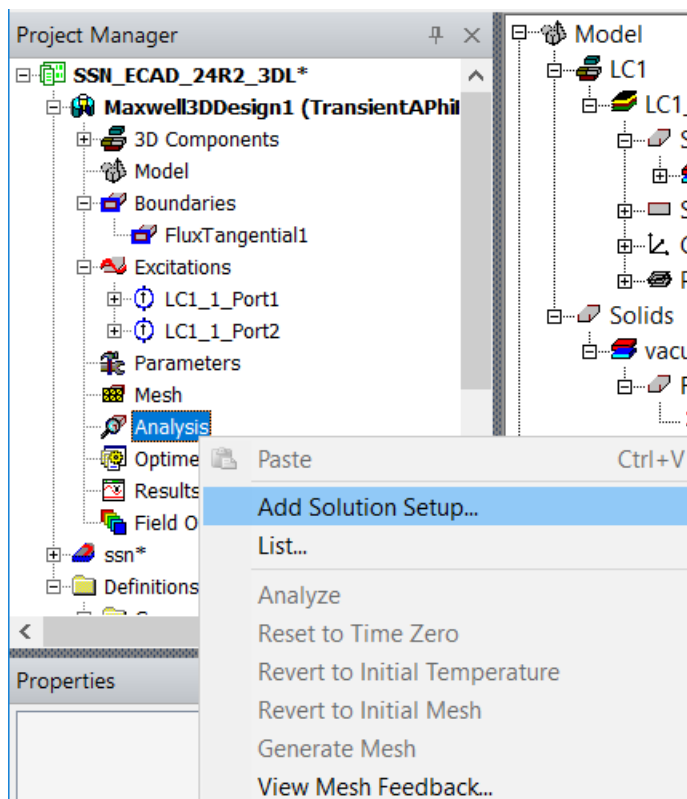

The **Solve Setup** window appears.

2. From the **General** tab:

- a. Set the Stop time to $2*(1/10000)$, and set the units to **s**.
- b. Set the Time step to $1/10000/30$ **s**.

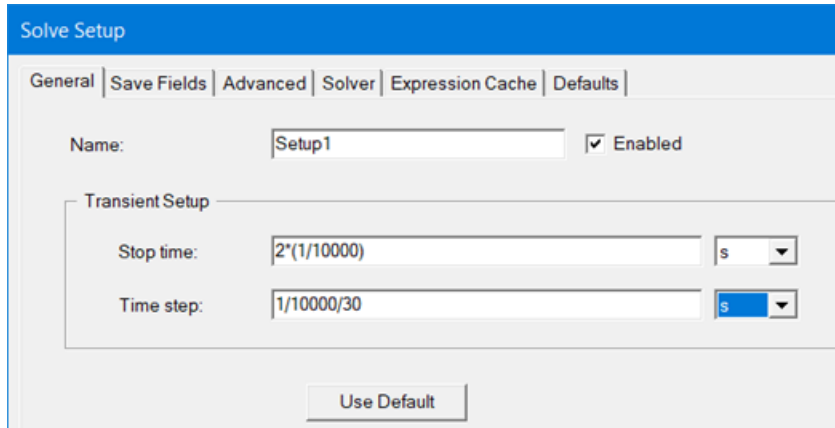

3. Click on the **Save Fields** tab.
4. Select Every 1 steps from 0 s to $2*(1/10000)$ s.

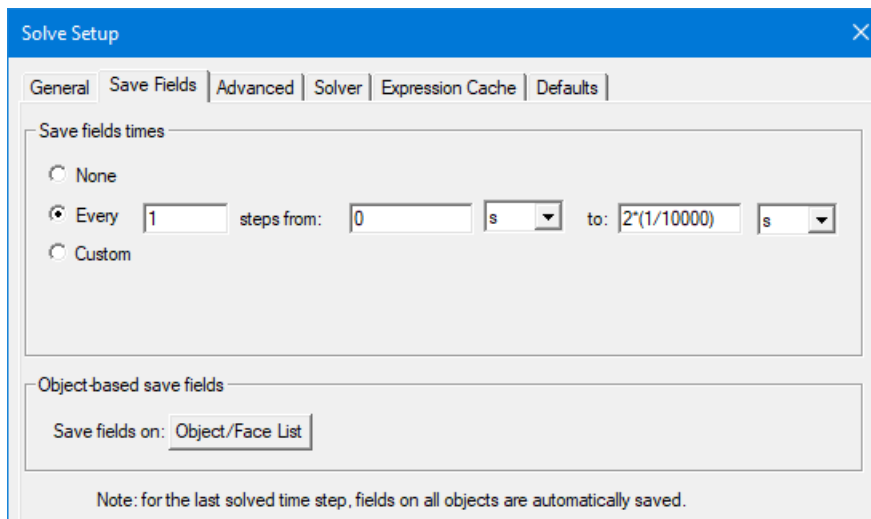

5. Leave other settings to the default, and click **OK**.

Set Up Force Calculation for Layout Component

The layout force is caused by current carrying traces that interact with AC field generated by other sources on the PCB board. This interaction generates Lorentz force, which can cause mechanical vibration and resonance that leads to potential board fatigue, electrical performance

malfunctioning, and failures. In the steps below, you will configure Maxwell to output these force results.

1. In the Project Manager tree, right-click on **Parameters**, and select **Assign > Force from Layout**.
2. In Layout Force Setup window:
 - a. Select all the layers for the VCC net.

Note: To select all the layers for a net, click on its name in the nets column.

- b. Set its Name as **F_VCC**.

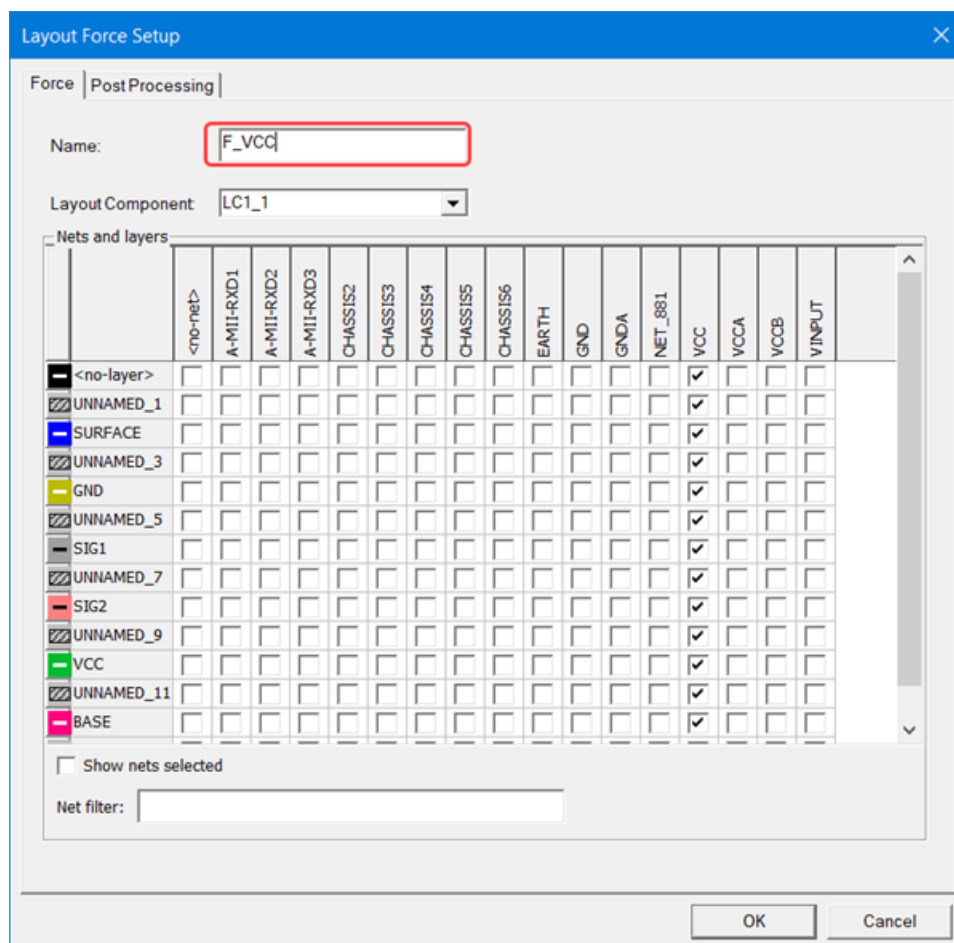

- c. In **PostProcessing** tab, select **Global** for Reference CS.

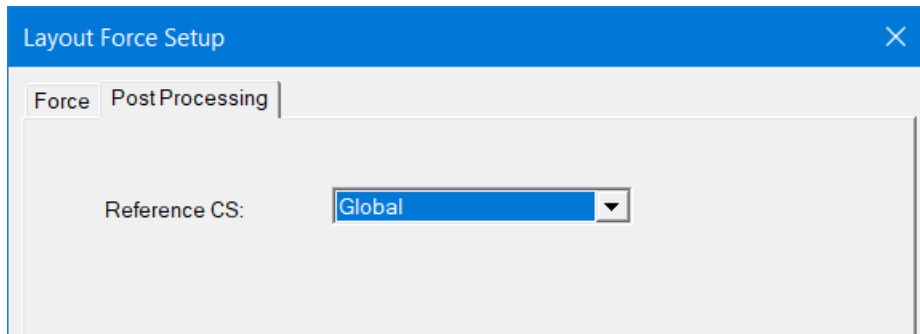

- d. Click **OK**.
3. Repeat the above process for GND force parameter setup.

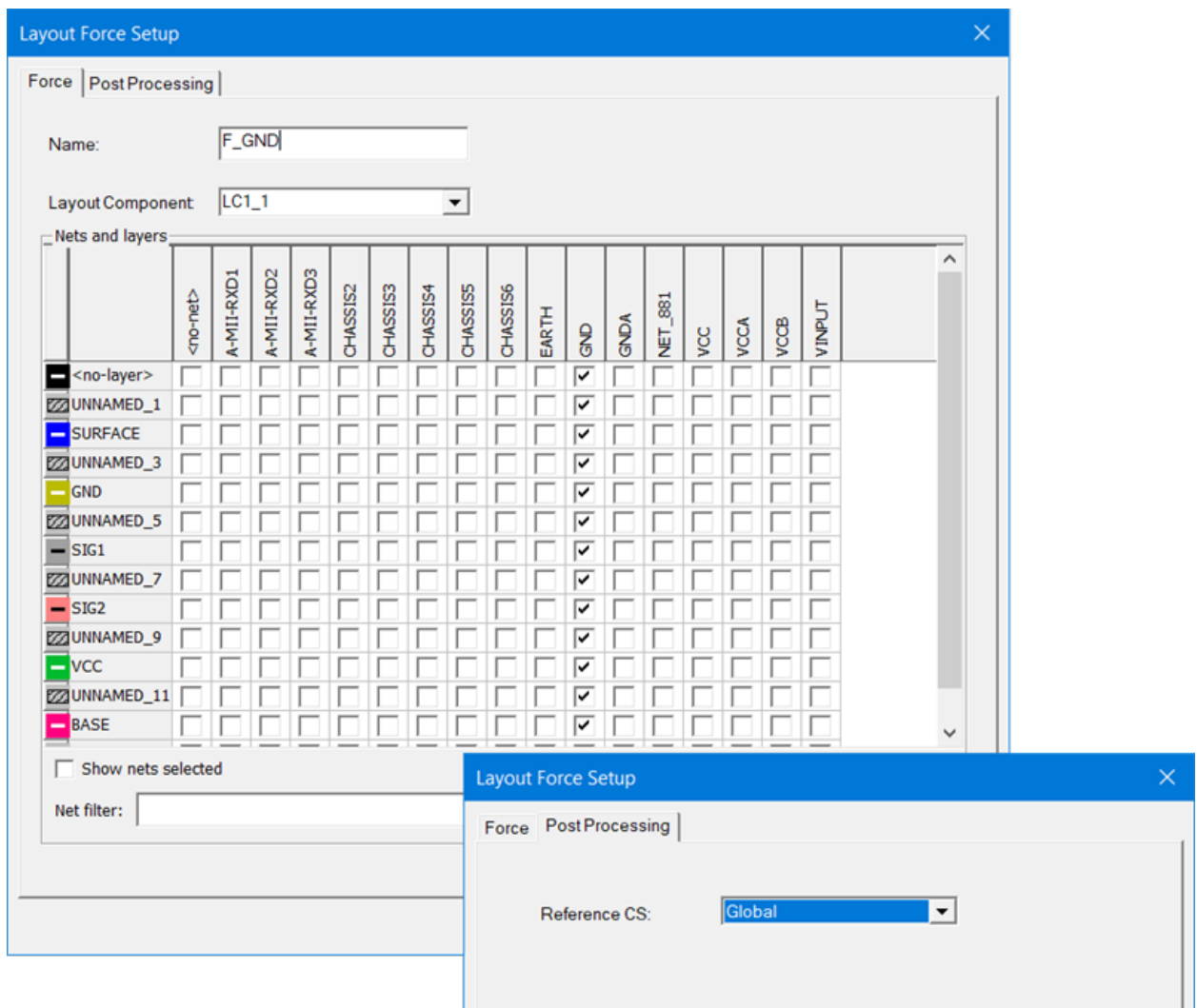

Enable Harmonic Force Calculation

Harmonic force data can be exported from a Maxwell simulation for further mechanical vibration analysis, for example, in Ansys Mechanical. Harmonic force is not calculated by default; it must be enabled before running the simulation.

1. From the Project Manager tree, right-click on the **Maxwell3DDesign** entry, and select **Enable Harmonic Force Calculation**.
2. From the Enable Harmonic Force Dialog window's **General** tab, for Type, select **Element Based (Volumetric)**.

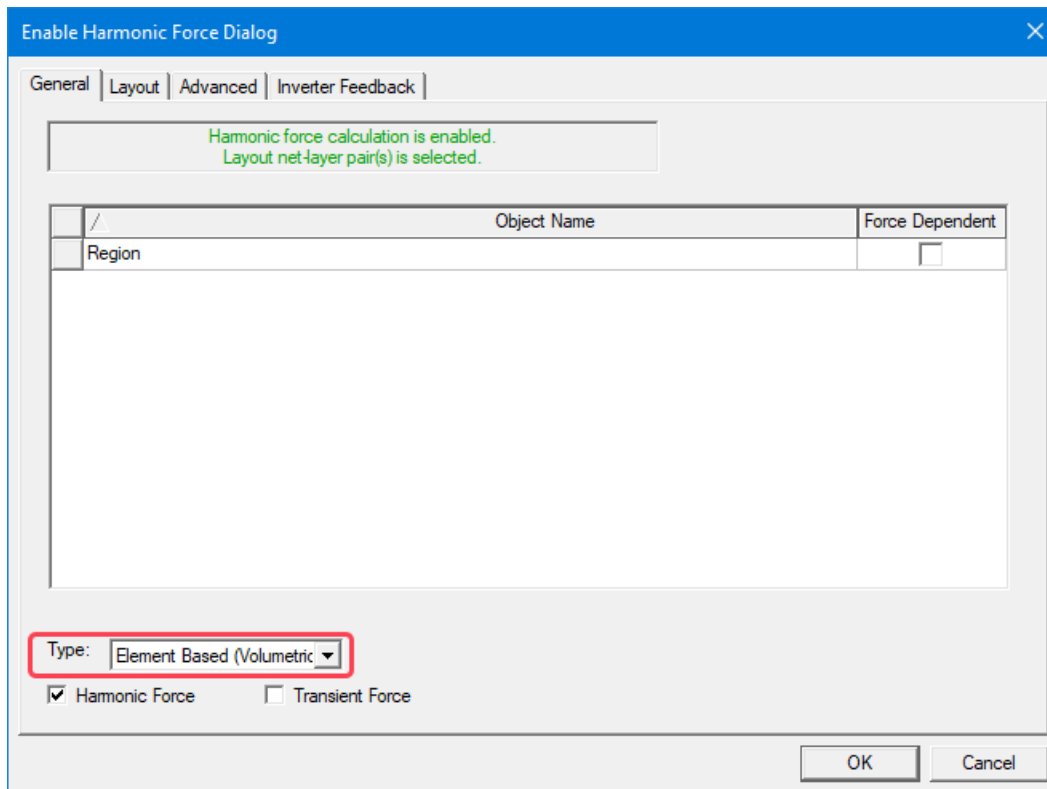

3. Click on the **Layout** tab, select the **GND** and **VCC** nets to be calculated.

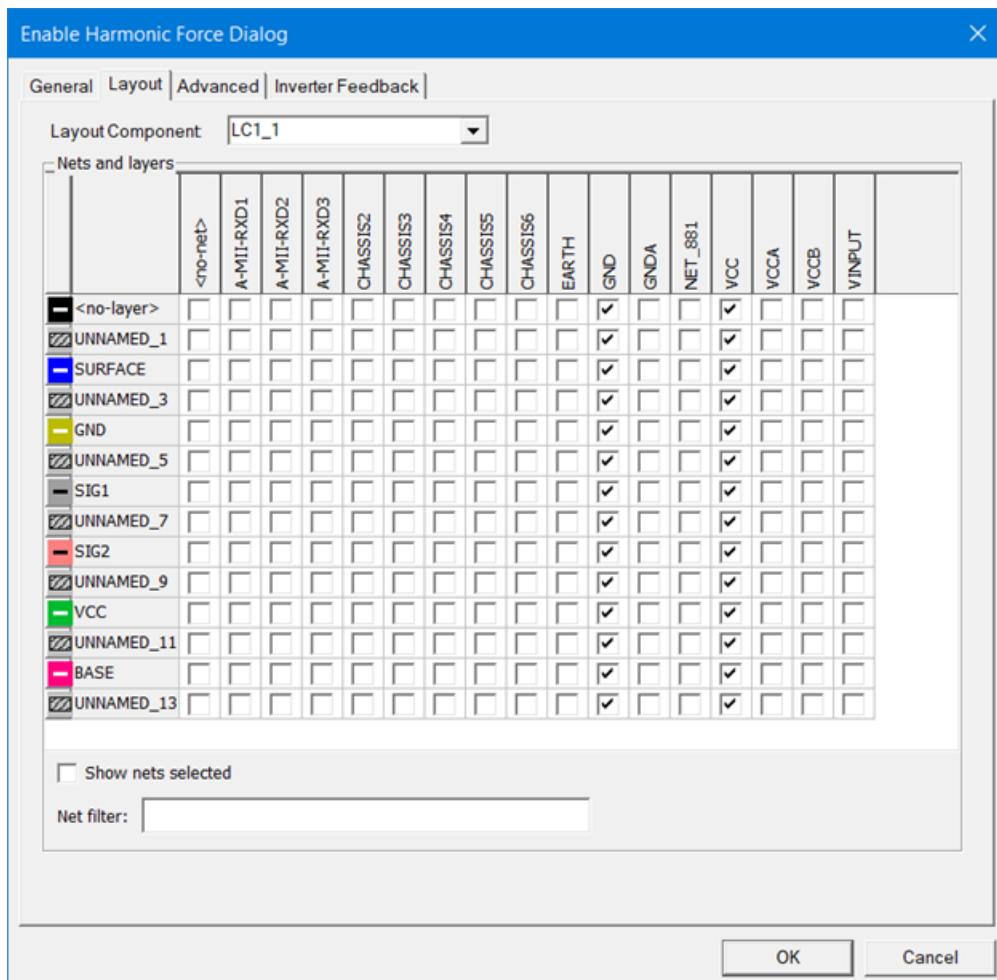

4. Click on the **Advanced** tab, and set the Start At and Stop At settings as shown below, and click **OK**.

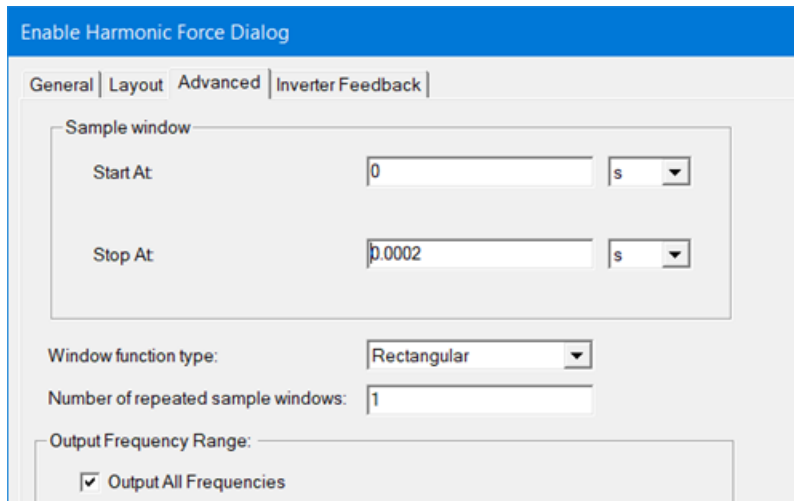

Validate Design and Run Simulation

Before running a simulation, it is best to validate its setup.

1. From the **Maxwell 3D** menu, select **Validate Check**.



Alternatively, from the **Simulation** tab, you can click the **Validate** icon.

The **Validate Check** tool runs, and after it is complete, the Validate Check window appears:

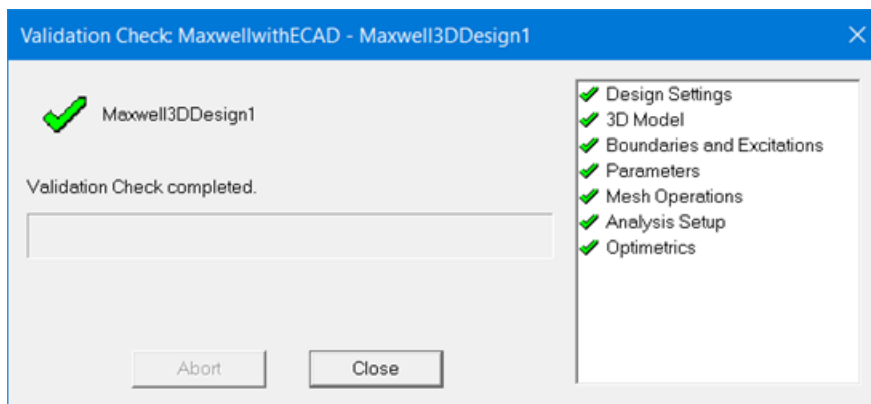

For this model, we see that the model, the design settings, and the simulation parameters were checked and validated. If the tool finds any problem with your design, it will be reported in this window. Make sure to address any of these issues before you run your

simulation.

2. Start the analysis: right-click on the **Analysis\Setup1** entry, and select **Analyze**.

Note: This simulation took about 3 hours on a Windows 10 machine with an Intel i7 2.10 GHz processor and 64 GB of RAM. To improve simulation time, Ansys recommends that you use the [Time Decomposition Method \(TDM\)](#). This feature requires additional licensing; contact your Ansys support representative for more details.

Note: If you are rerunning a transient simulation that does not have any changes to the simulation parameters, you need to **Reset to Time Zero**; otherwise, Maxwell will not overwrite the data that is already present because it will not rerun the simulation. You may need to do this when you upgrade a project to a newer version of Ansys Electronics Desktop and want to rerun your simulations.

To reset to time zero, click **Maxwell > Analysis Setup > Reset to Time Zero**, or in the Project Manager tree, right-click **Setup** under **Analysis**, and select **Reset to Time Zero**.

5 - Analyzing the Solution

Now that you have generated a solution for the PCB design, you can analyze it using Maxwell postprocessing features. In this section, you will

- plot the layout force and terminal current for the VCC and GND nets
- visualize the flux density and current density

Plot the Force and Current

After your simulation is finished, you will postprocess the results to view the Layout Force and the Terminal Current.

1. In the Project Manager tree, right-click on **Results**, and select **Create TransientAPhiFormulation Report > Rectangular Plot**.
2. In the Report window:
 - a. For the Category, select **Layout Force**.
 - b. For the Quantity, use the **Ctrl** key to select **F_GND.Force_mag** and **F_VCC.Force_Mag**.

c. Click **New Report**.

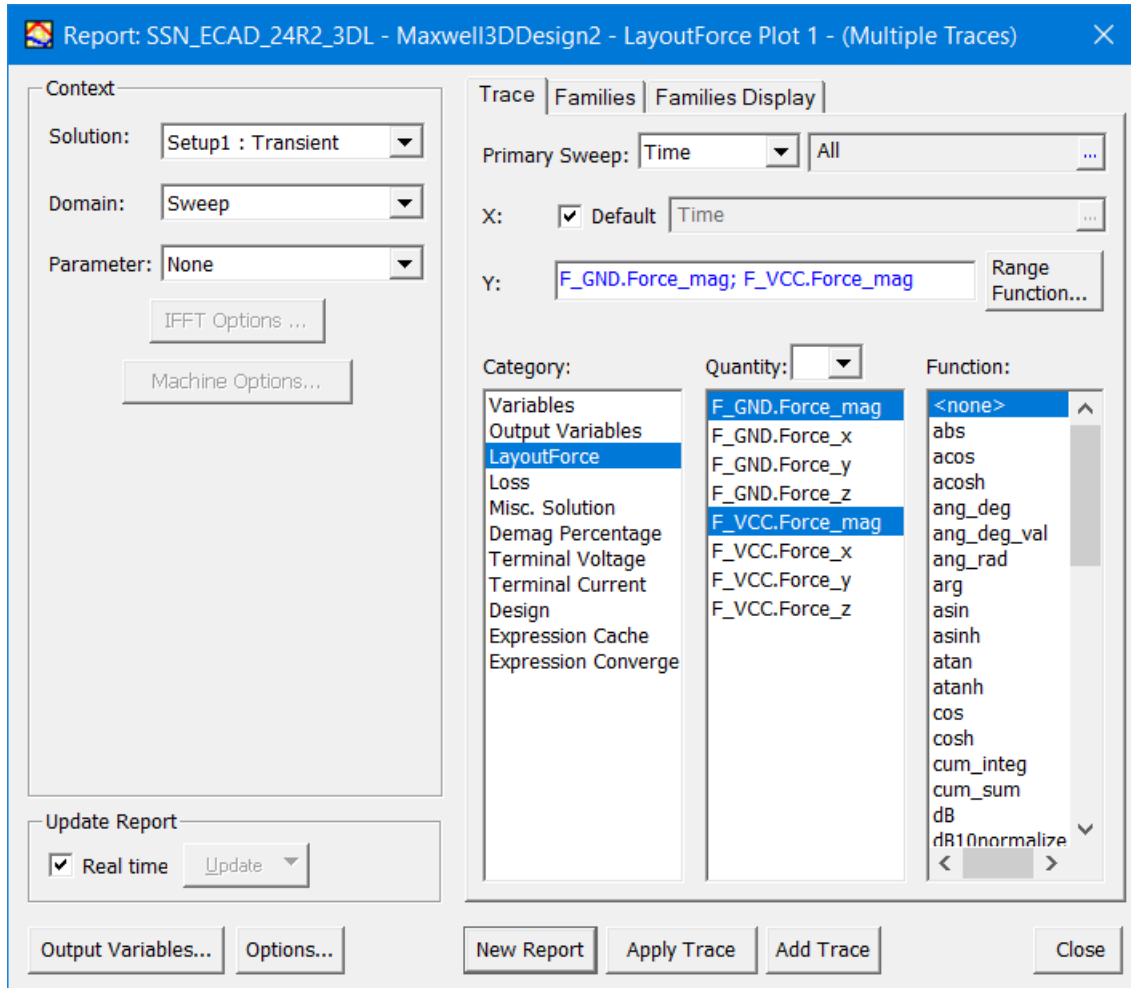

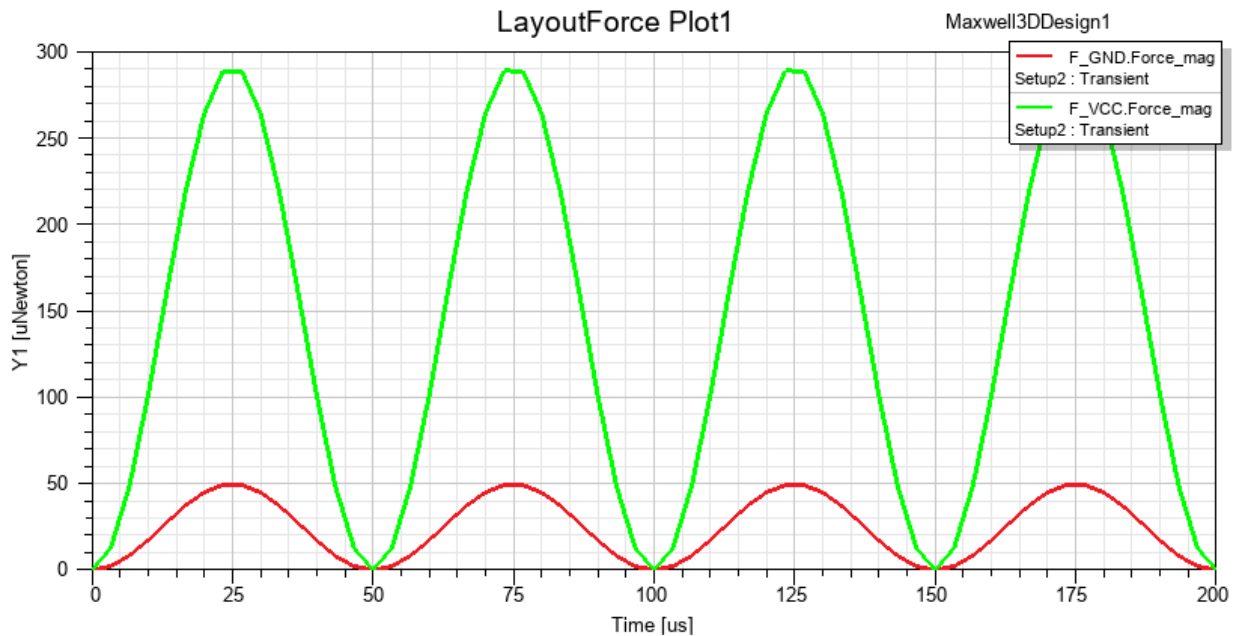

3. Plot the terminal current for both ports:

- For the Category, select **Terminal Current**.
- For Quantity, select **TerminalCurrent(LC1_1_Port1_T1)** and **TerminalCurrent(LC1_1_Port2_T1)**.
- Click **New Report**.

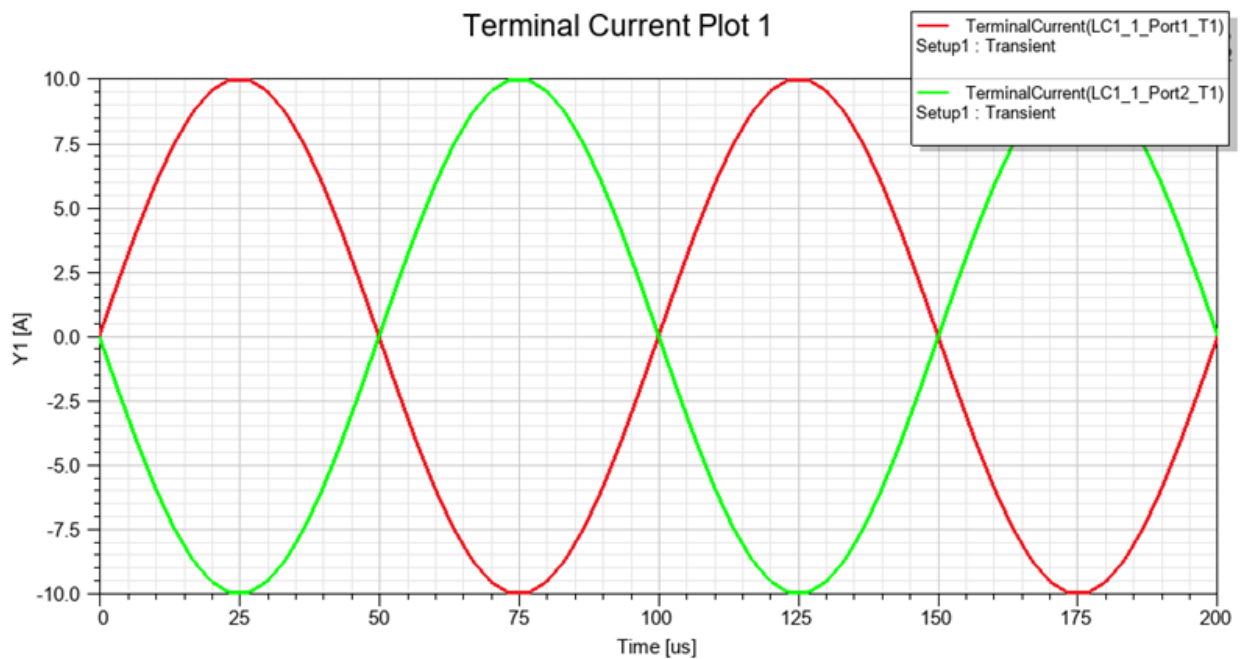
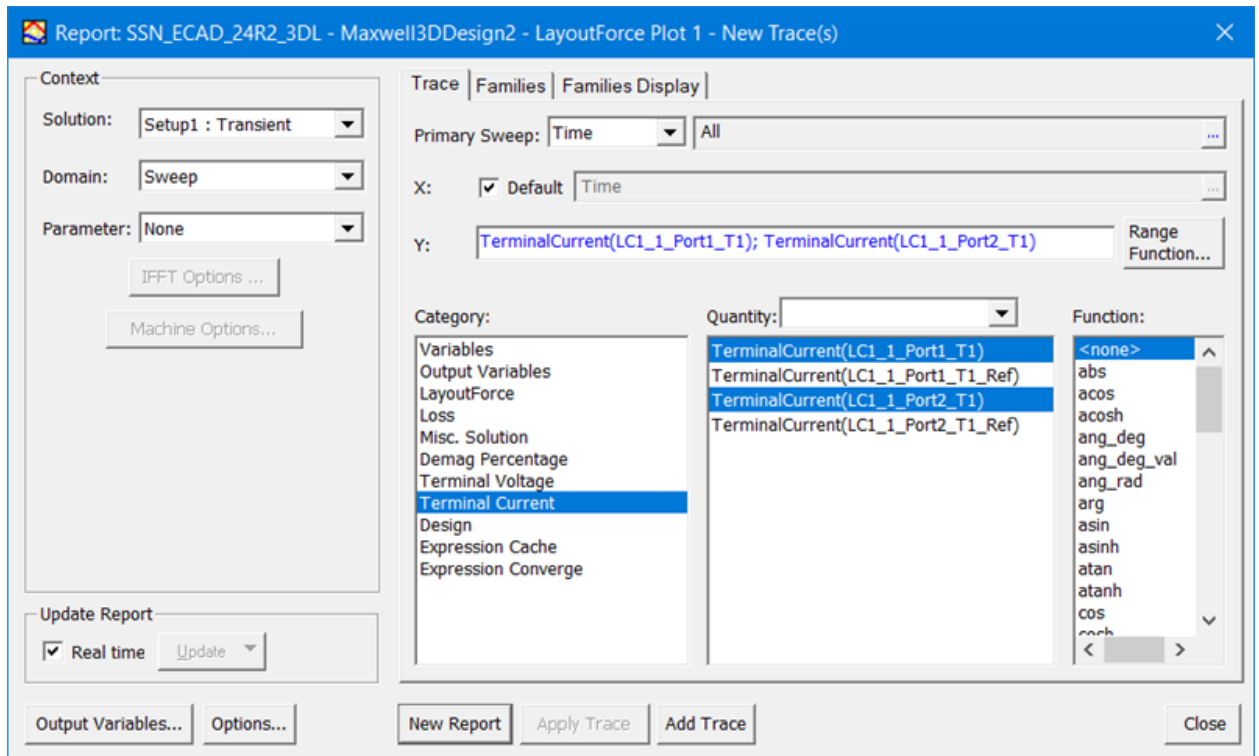

Note: If you see a transient spike at first two time steps, it can be ignored as it is a numerical artifact. You can adjust the time scale to eliminate the numerical artifact using the **Zoom Area** icon from the Desktop's **View** tab.

For a more precise range, right click in the plot window and select **Modify Report**, then click on the ... icon beside the Time field to open a dialog box for specifying a time range.

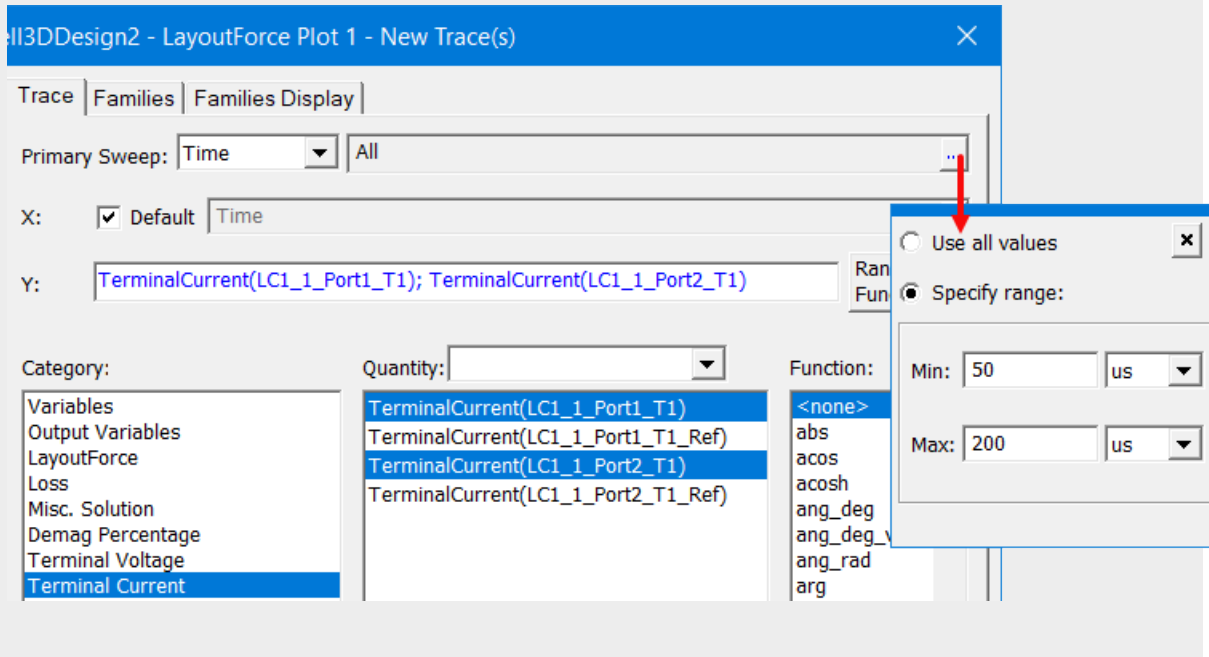

Field Visualization

Next you will plot the flux density and current density results for visualization.

1. In the Project Manager tree, right click on **Field Overlays** and select **Fields > B > Mag_B**.
2. In the Create Field Plot window:
 - a. Select **Plot on surface only**.
 - b. Click on the **VCC** column label to select all the selectable layers (not all of them are displayed in the illustration).

c. Click **Done**.

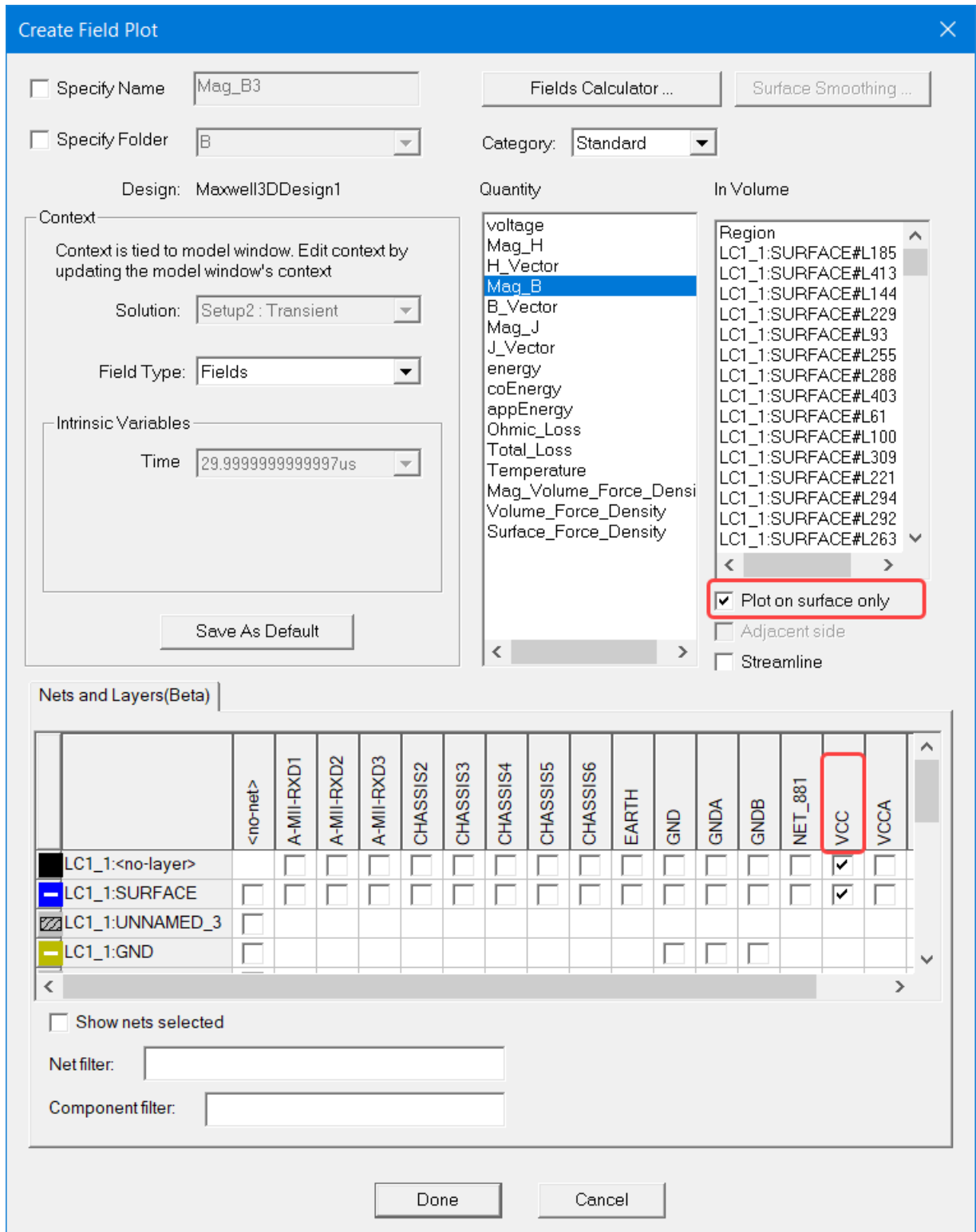

- Click on the timestamp in the display window, and from the Set View Context window that opens, select 30 us.

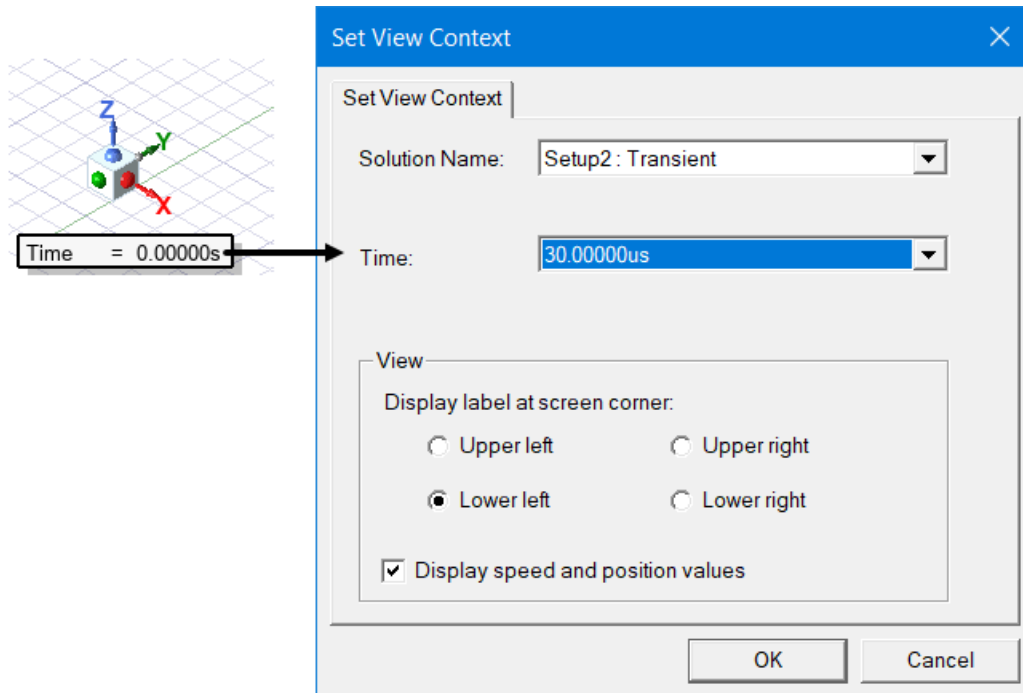

- Right click on the Plot legend, and select **Modify**.
- Click on the **Scale** tab, and set the scale to **Log**.

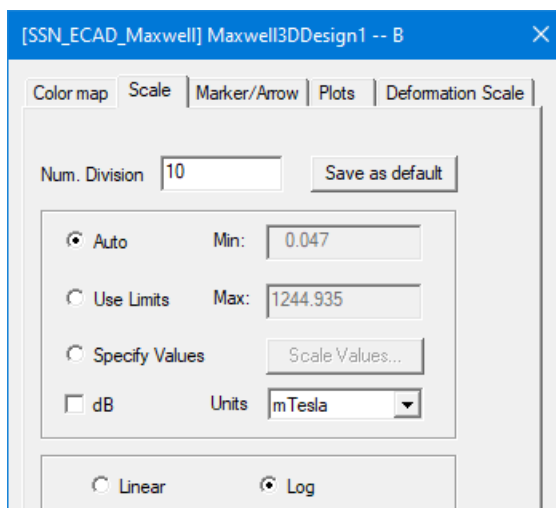

The resulting flux density plot for the VCC net is shown below:

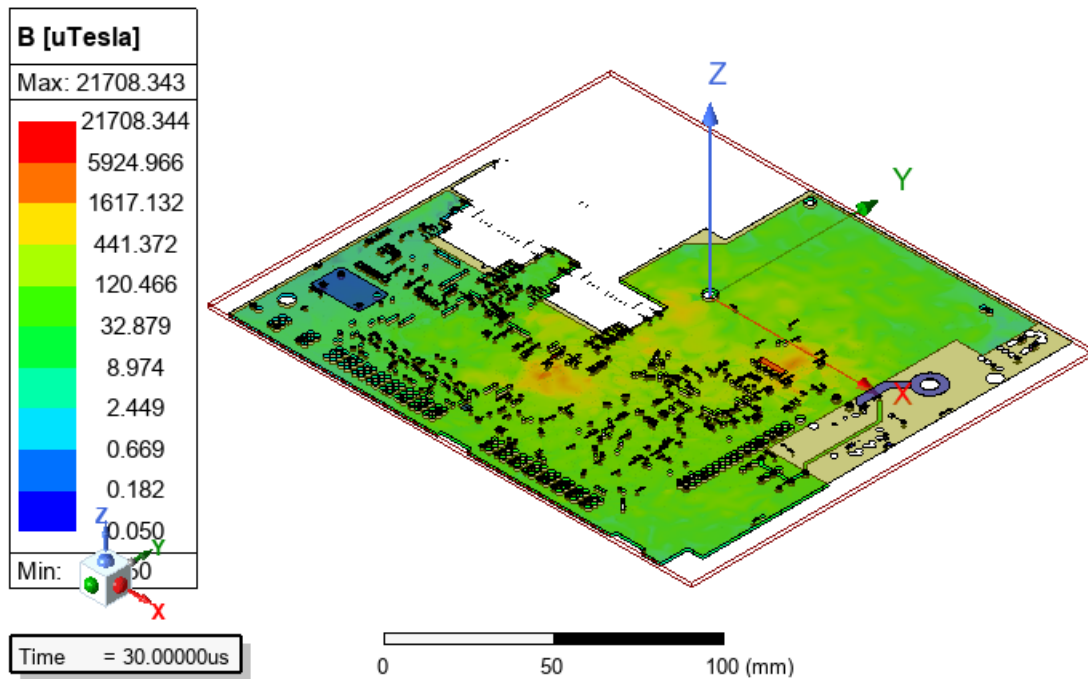

Note: If you would like to hide the Region (it is hidden in these illustrations), right click on it in the model history tree, and select **View > Hide in Active View**.

6. Plot the VCC **Mag_J** results. Remember to set the scale to **Log**.

Note: To avoid plotting the Mag_J results in the same plot as the Mag_B results, right click on the **Mag_B** entry in the **Field Overlays\B** folder, and uncheck the **Plot Visibility** option.

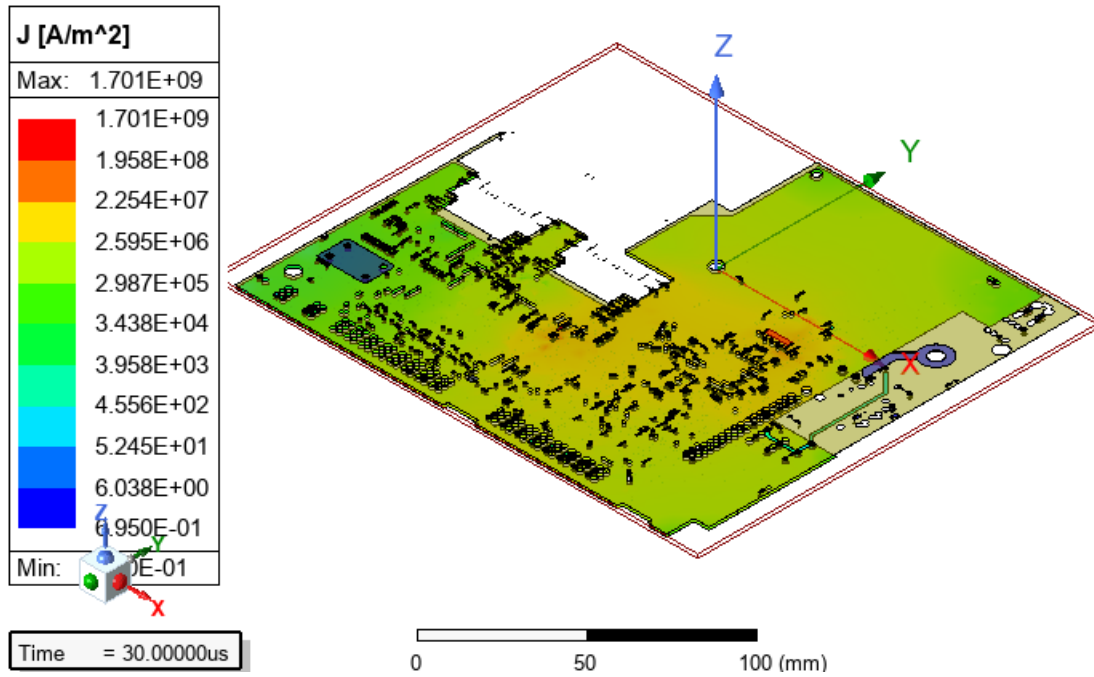

7. Plot the VCC J_Vector results.

You may also need to adjust the arrow size to make the vectors more visible; this can be done from the Modify > **Marker/Arrow** tab.

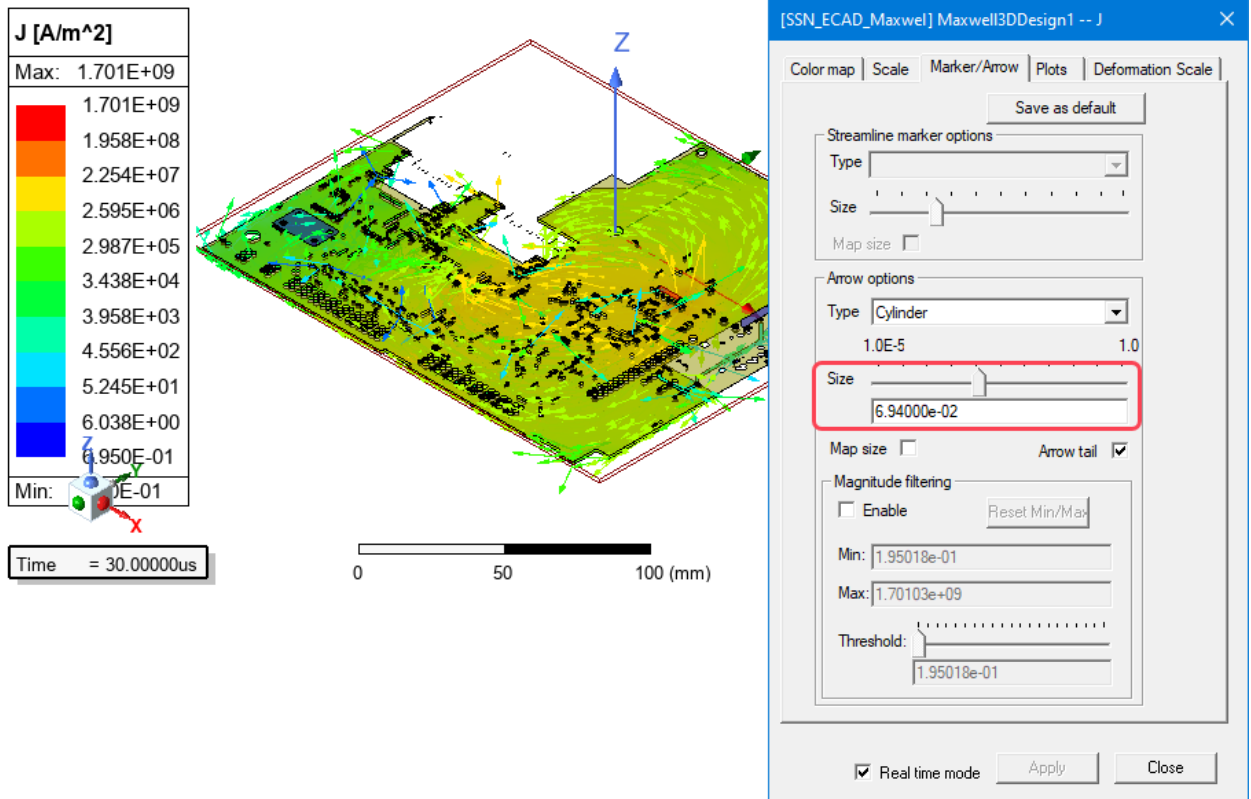

8. Repeat the above process for the GND **Mag_B**, **J_Mag**, and **J_Vector** plots.

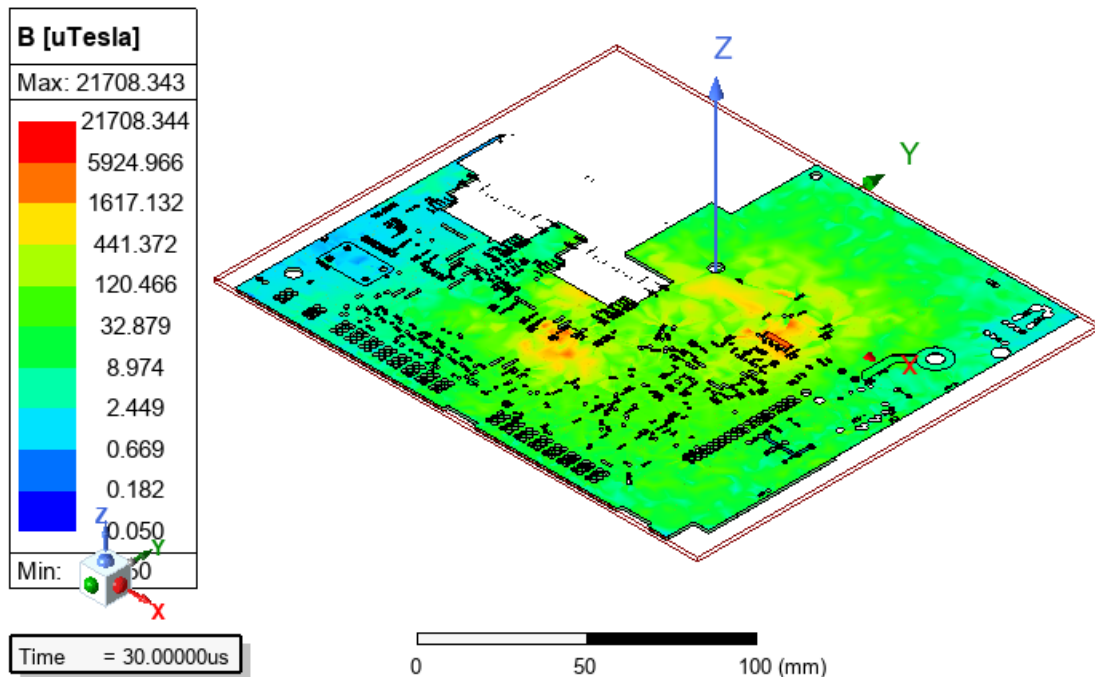

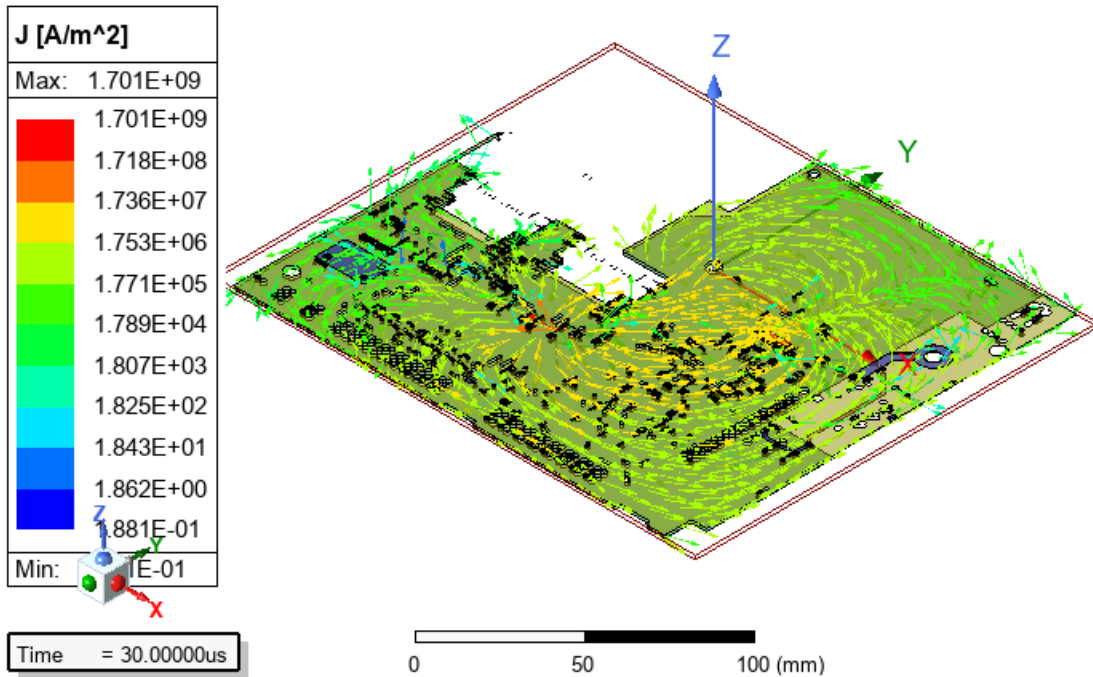
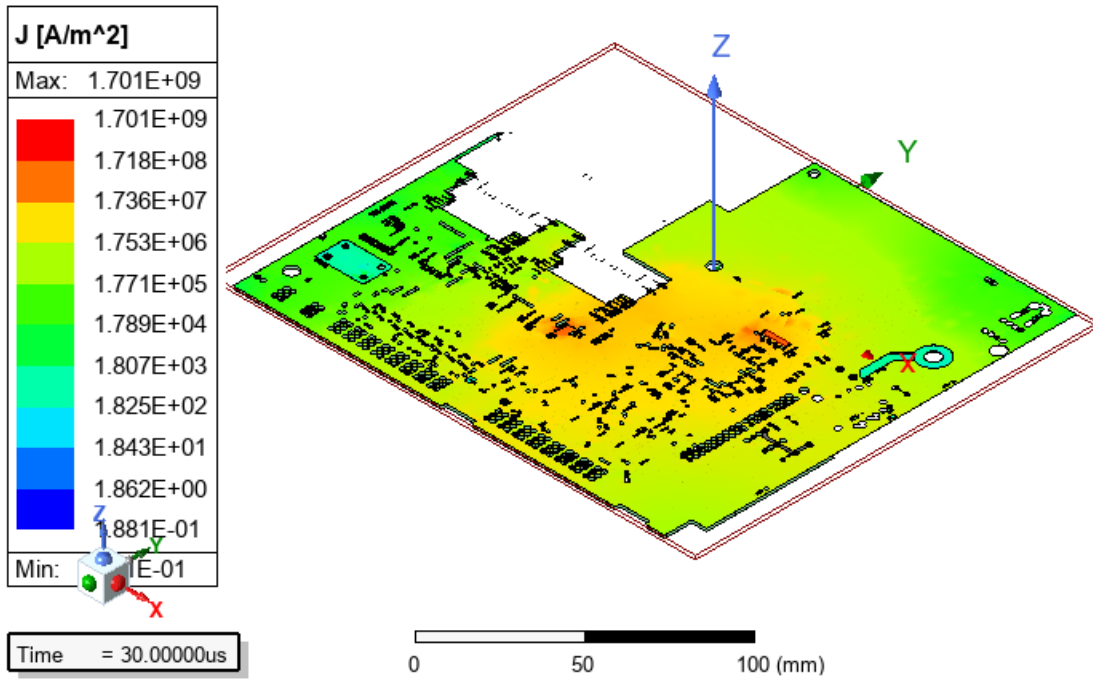

Export Harmonic Force Data

Harmonic force data can be exported for use in other tools such as Ansys Mechanical. To be able to export this data, you first had to enable its calculation before you ran your simulation; see [Enable Harmonic Force Calculation](#) for more details.

1. From the menu bar, select **Maxwell 3D > Export Transient /Harmonic Force**.
2. From the **General** tab, define the export type, solution setup, and file path as shown below.

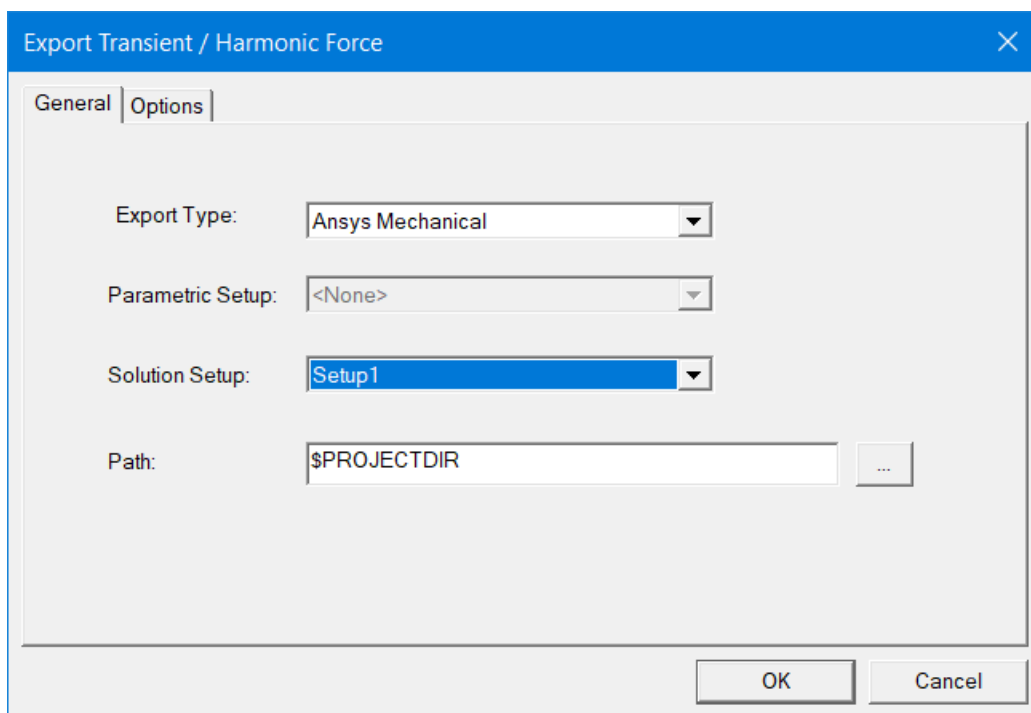

3. From the **Options** tab, check the **Output All Frequencies** option.

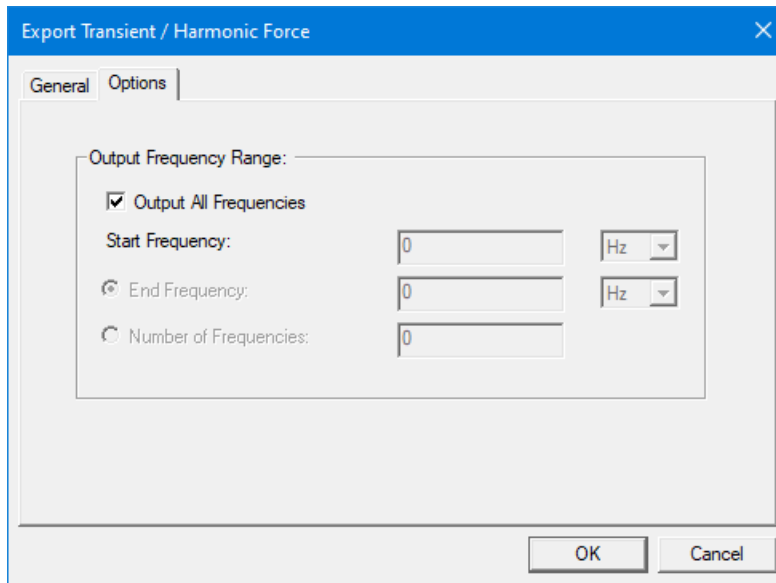

4. Click **OK** to save the data in .csv format.

Warning: Because there is a significant amount of data to export, this operation may take several minutes.

The index.csv file that is in your top-level project directory reports the location of the exported data. For this simulation, the Maxwellharforce.csv file is saved to a \\Setup1\\DV4 directory in the project folder.

	A	B	C	D
1	Setup Name	Directory		
2	Setup1	Setup1\DV4		
3				

	A	B	C	D	E	F	G	H	I	J
1	xc(m)	yc(m)	zc(m)	volume(m ³)	bfx_re(N/m)	bfx_im(N/m)	bfx_re(N/m)	bfx_im(N/m)	bfz_re(N/m)	bfz_im(N/m)
2	-0.092999	-0.07312	0.001657	9.55912	0.011869	0	-0.02245	0	0.000685	0
3	-0.092872	-0.07328	0.001657	9.55912	0.01184	0	-0.02245	0	0.000732	0
4	-0.092666	-0.0732	0.001657	5.97445	0.011716	0	-0.02228	0	0.001082	0
5	-0.092872	-0.07312	0.00163	9.55912	0.003808	0	0.000788	0	-0.0151	0
6	-0.092999	-0.07328	0.00163	9.55912	0.003261	0	0.000765	0	-0.01036	0
7	-0.092666	-0.0732	0.00163	5.97445	0.003193	0	0.00097	0	-0.01356	0
8	-0.092872	-0.07344	0.001639	9.55899	0.001943	0	0.000608	0	-0.00636	0
9	-0.092999	-0.07344	0.001648	9.55899	0.000803	0	5.341571	0	-0.00255	0
10	-0.092999	-0.07296	0.001639	9.55925	0.002592	0	0.000424	0	-0.01105	0
11	-0.092872	-0.07296	0.001648	9.55925	0.012966	0	-0.02206	0	-0.00599	0
12	-0.092964	-0.07284	0.001652	5.73547	0.001808	0	0.001167	0	-0.01118	0
13	-0.093091	-0.07284	0.001634	5.73547	0.020209	0	0.035998	0	-0.02285	0
14	-0.093091	-0.07279	0.001643	5.73547	0.00772	0	0.059041	0	-0.02404	0
15	-0.092837	-0.07274	0.001634	1.14709	-0.00486	0	0.073454	0	-0.00183	0
16	-0.094001	-0.07307	0.001634	7.64074	-0.00155	0	-0.01718	0	-0.01367	0
17	-0.093879	-0.07365	0.001634	2.06736	0.080309	0	0.285719	0	-0.46683	0

Maxwellharforce +

6 - Combining ECAD and MCAD

You can add components to an imported ECAD design. In this section you will create a permanent magnet using Ansys Electronics Desktop MCAD tools and rerun your simulations to see the effect the magnet has on the PCB board.

Create Permanent Magnet

To create the permanent magnet, you will use Maxwell's MCAD tools to draw it, and then assign a material to it.

1. From the Draw menu, select **Box**. If the non-model object warning pops up, select **No**.
2. If needed, to open the CreateBox dialog box, press **F4** on keyboard.
3. Set the following:
 - a. **Position**: -14, -32.6, 1.7
 - b. **XSize**: 20
 - c. **YSize**: 20
 - d. **ZSize**: 5
 - e. Click **OK**.

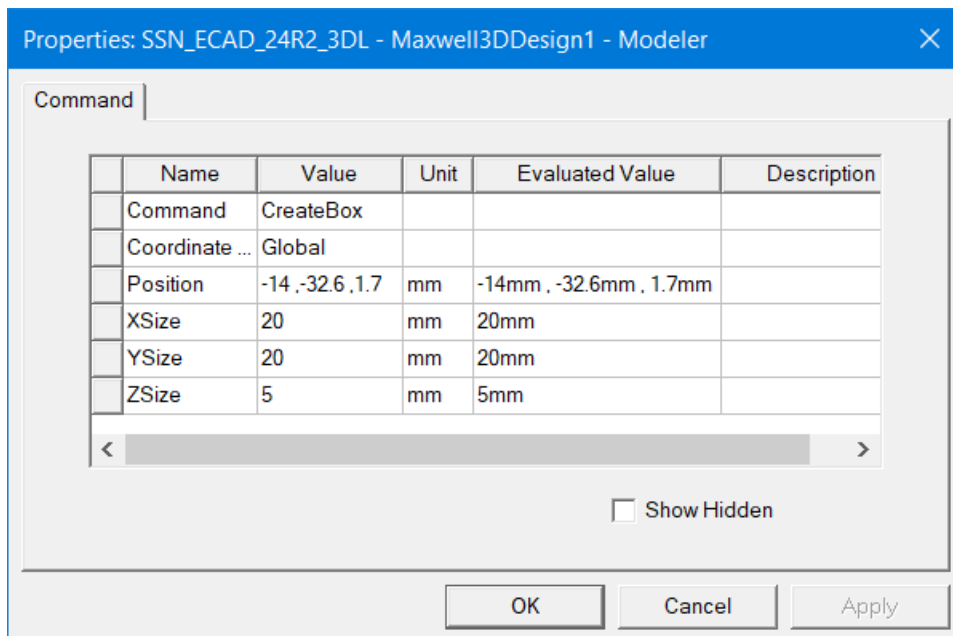

4. From the model history tree, double click on **Box1** to open its properties.
5. Change its **Name** to **Magnet**.
6. In the model history tree, right-click **Magnet**, and select **Assign Material**.

7. In the Select Definition window, search for *NdFe35*, then click **Clone Material(s)**.
8. In the View/Edit Material window:
 - a. Assign **NdFe35_Z** as the Material Name.
 - b. For the Magnitude vectors, assign X Component = 0, Y Component = 0, and Z Component = 1.
 - c. Click **OK** in the View/Edit Material and Select Definition windows.

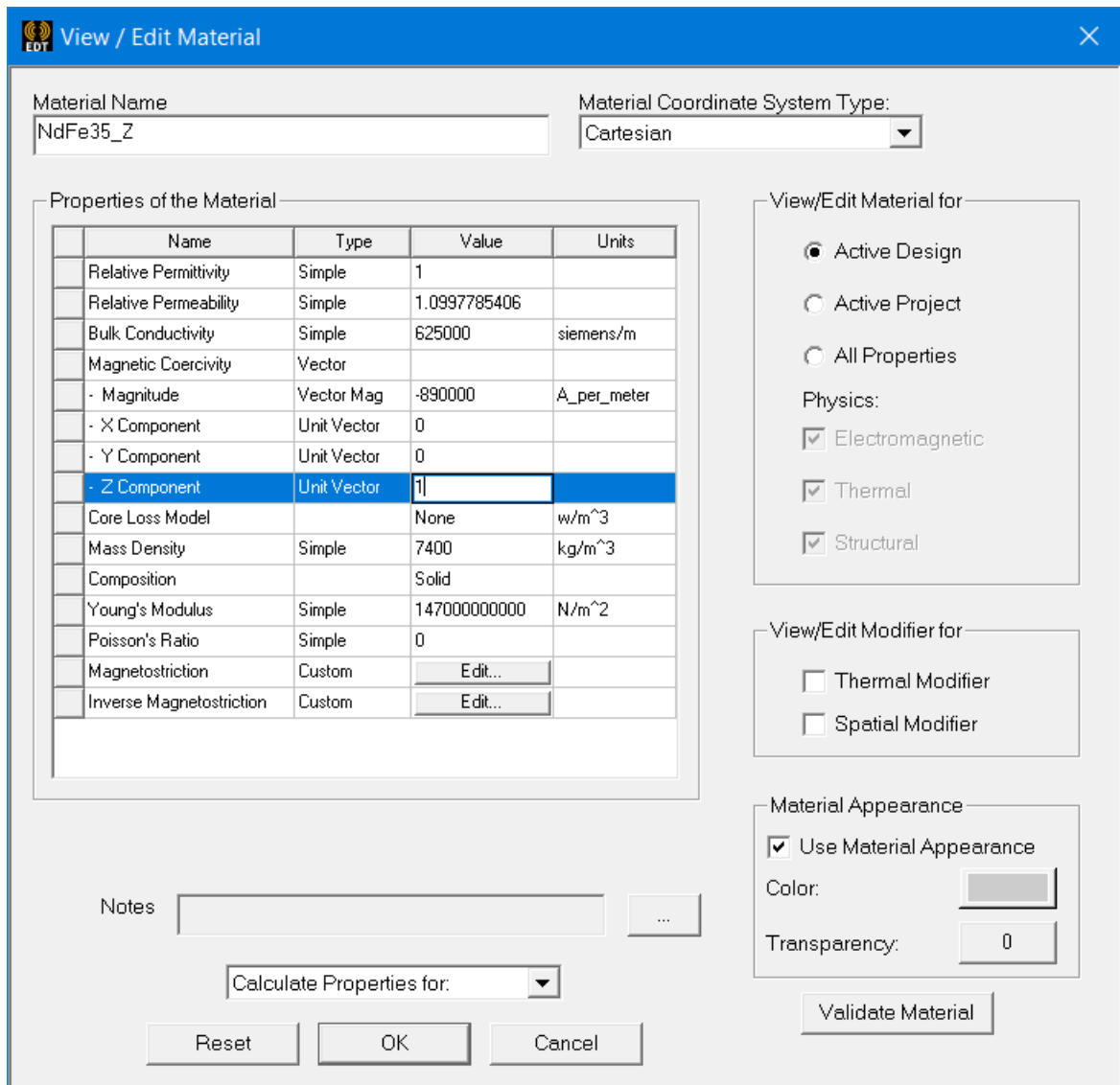

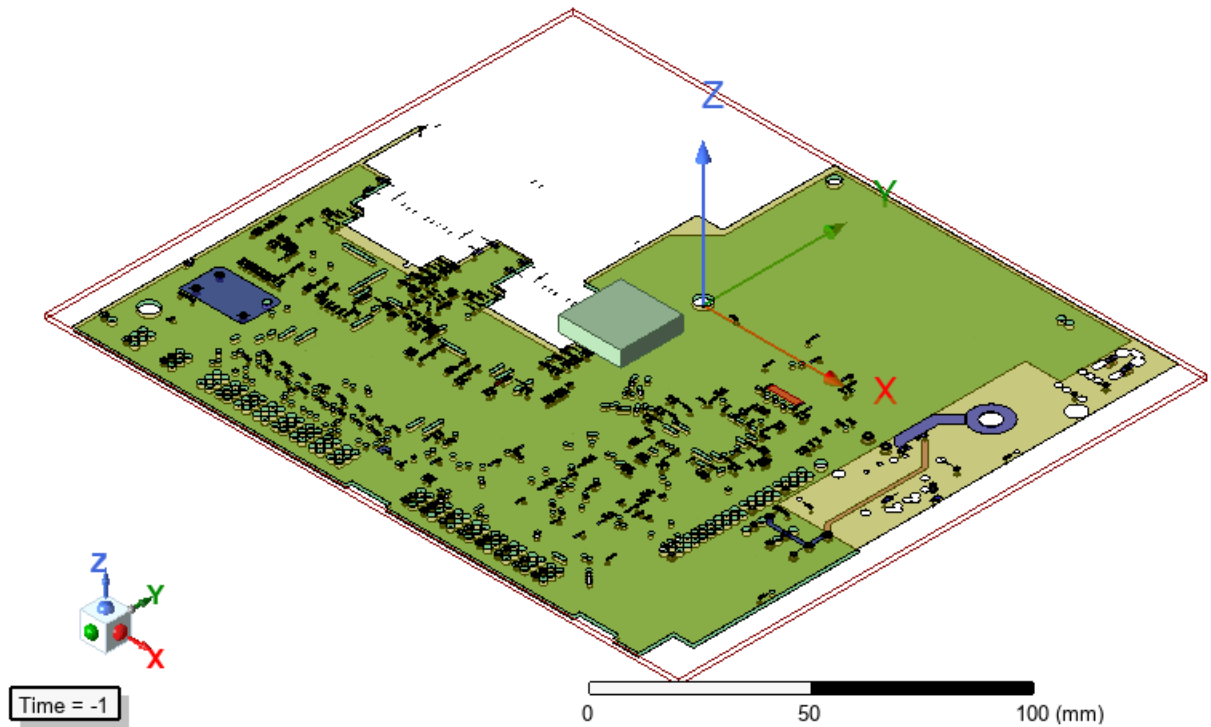

Assign Mesh to Magnet and Run Simulation

To assign a mesh to the permanent magnet:

1. In the model history tree, right click on **Magnet**, listed under the **NdFe35_Z** material, and select **Assign Mesh Operation > Inside Selection > Length Based**.
2. In the window that opens:
 - a. Check the **Set maximum element length** option.
 - b. Set the value to 1 mm.
 - c. Click **OK**.

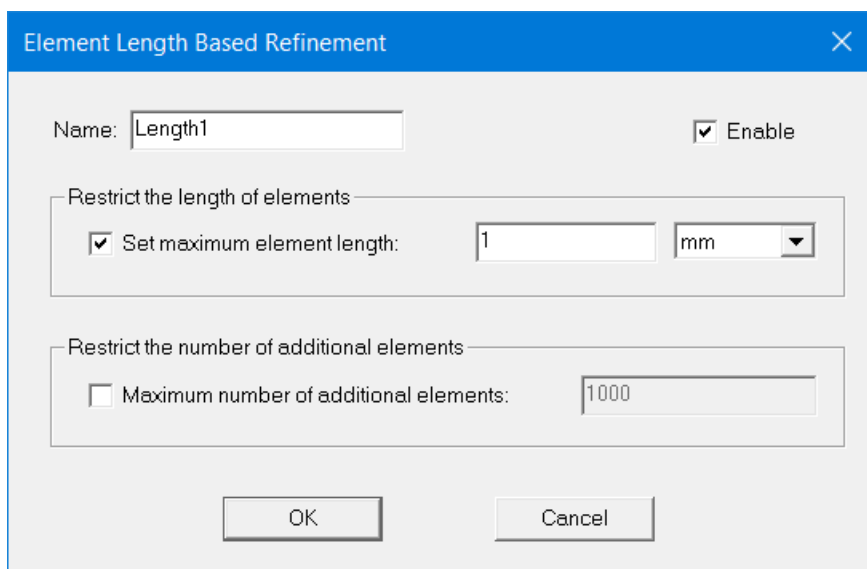

3. In the Project Manager tree, right click on **Setup1** (under **Analysis**), and select **Analyze**.

View Force and Current Results

1. In the Project Manager tree, right-click on **Results**, and select **Create TransientAPhiFormulation Report > Rectangular Plot**.
2. In the Report window:
 - a. For the Category, select **Layout Force**.
 - b. For the Quantity, use the Ctrl key to select **F_GND.Force_Mag** and **F_VCC.Force_mag**.
 - c. Click **New Report**.

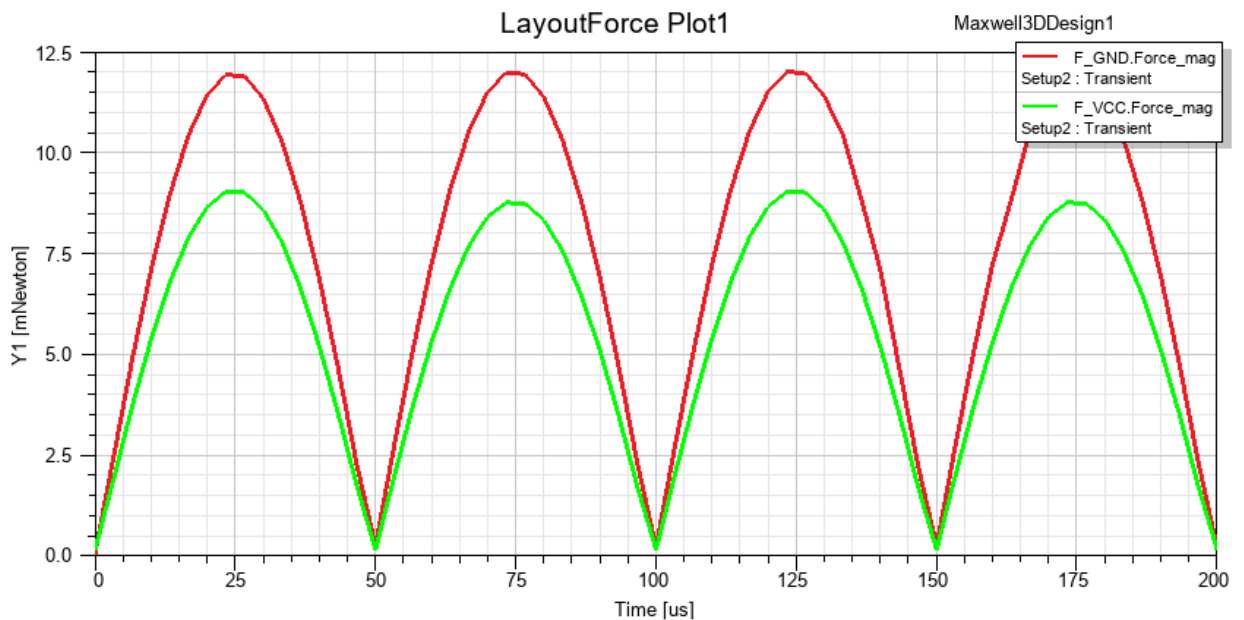
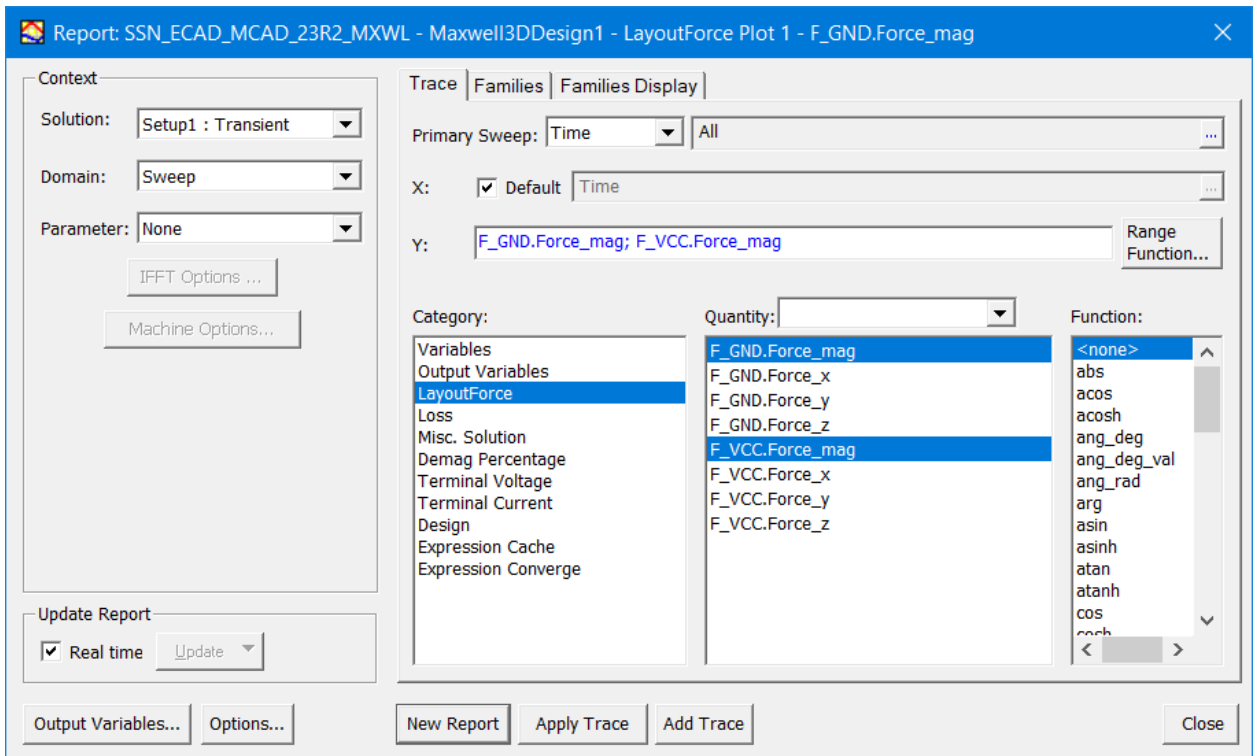

Note: Compare these results with the [results](#) obtained without a magnet.

3. Plot the terminal current for both ports:
 - a. For the Category, select **Terminal Current**.
 - b. For Quantity, select **TerminalCurrent(LC1_1_Port1_T1)** and **TerminalCurrent(LC1_1_Port2_T1)**.
 - c. Click **New Report**.

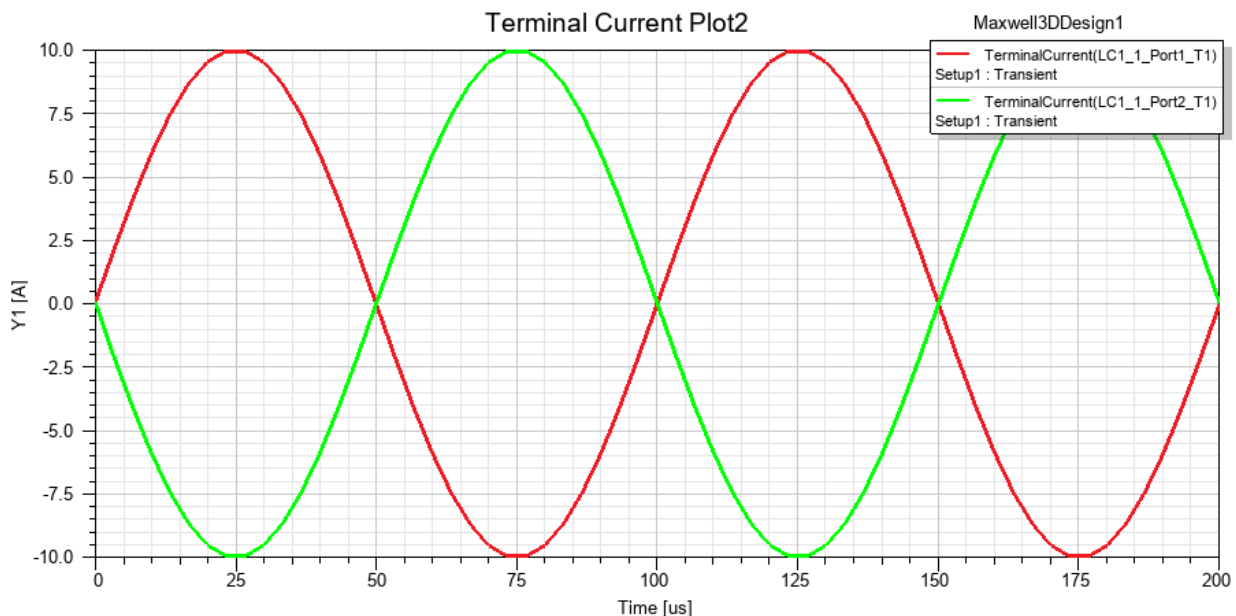

Note: If you see a transient spike at first two time steps, it can be ignored as it is a numerical artifact. You can adjust the time scale to eliminate the numerical artifact using the **Zoom Area** icon from the Desktop's **View** tab.

For a more precise range, right click in the plot window and select **Modify Report**, then click on the ... icon beside the Time field to open a dialog box for specifying a time range.

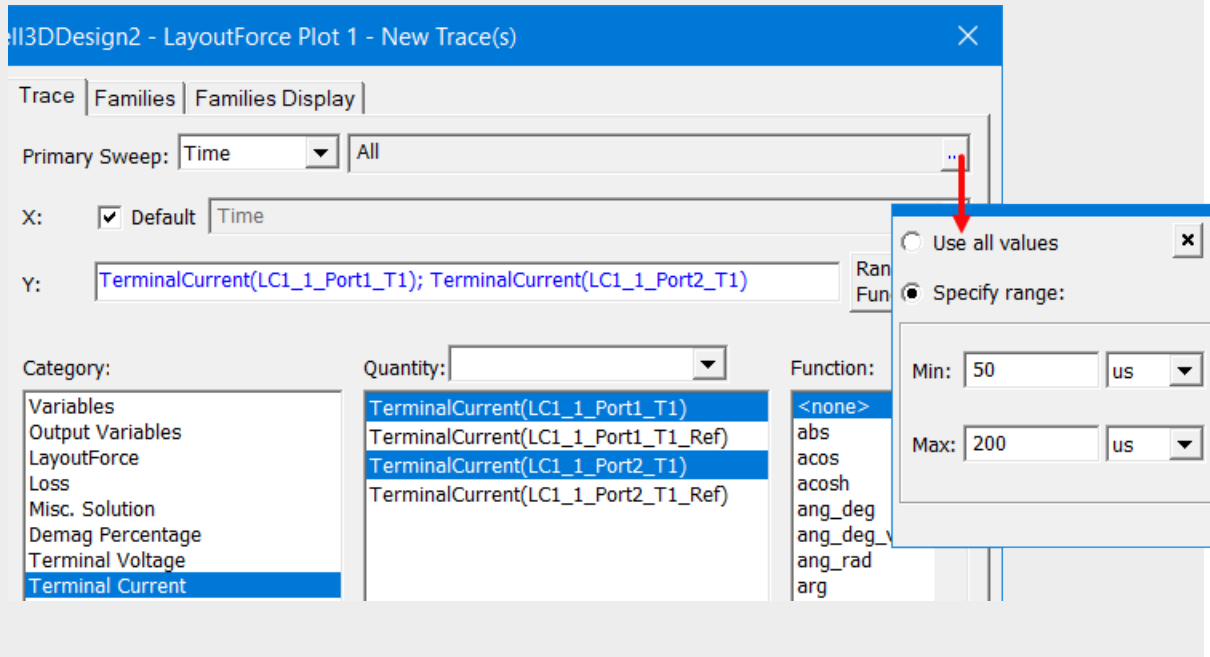

View Field Results on Magnet

1. In the **3D Modeler** window, right click on the Magnet, and select **Fields > B > Mag_B**.

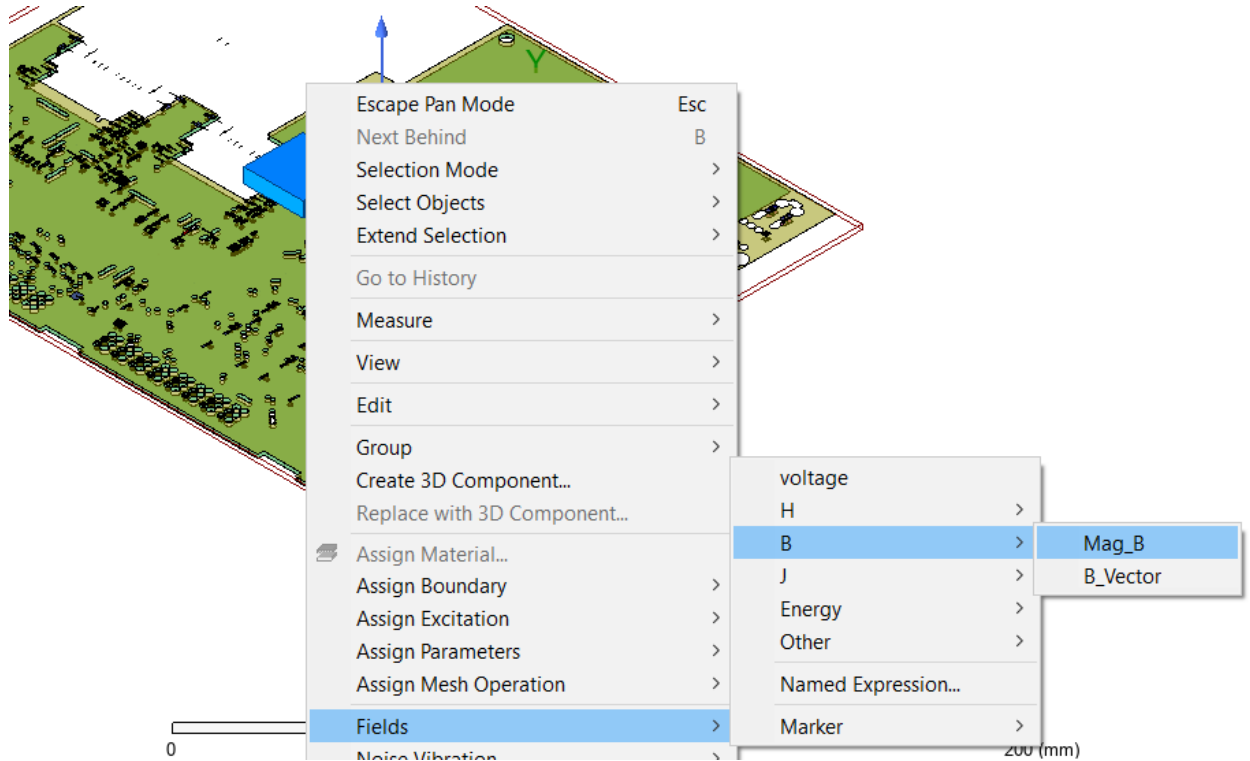

2. In the Create Field Plot window that opens:
 - a. Select **Mag_B** as the Quantity.
 - b. Select **Plot Surface Only**.
 - c. Click on the **GND** and **VCC** columns to select those nets.
 - d. Click **Done**.

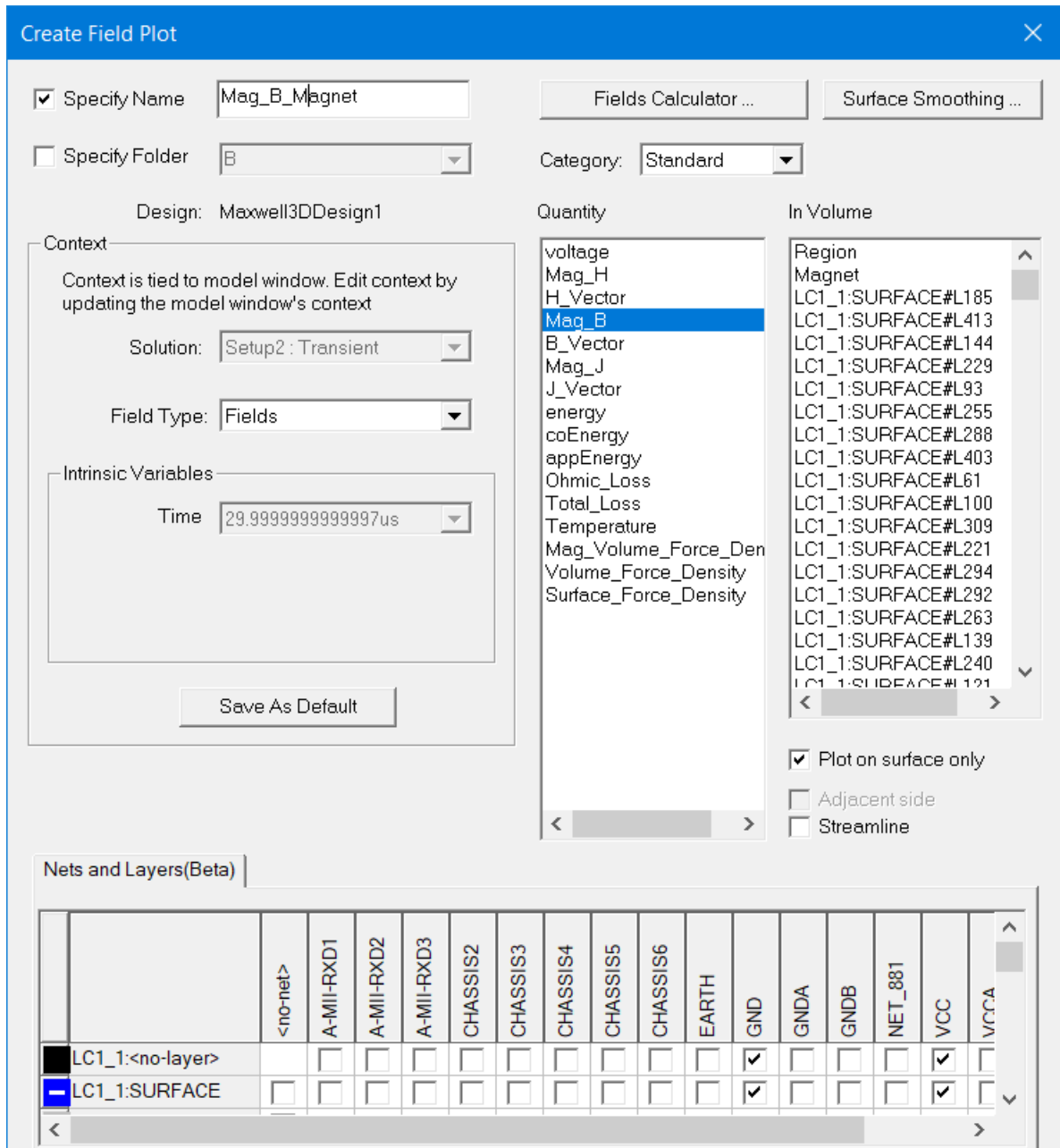

- Adjust the time step to 30 us, and set the color key scale to **Log**; if needed, see [Field Visualization](#) for more details.

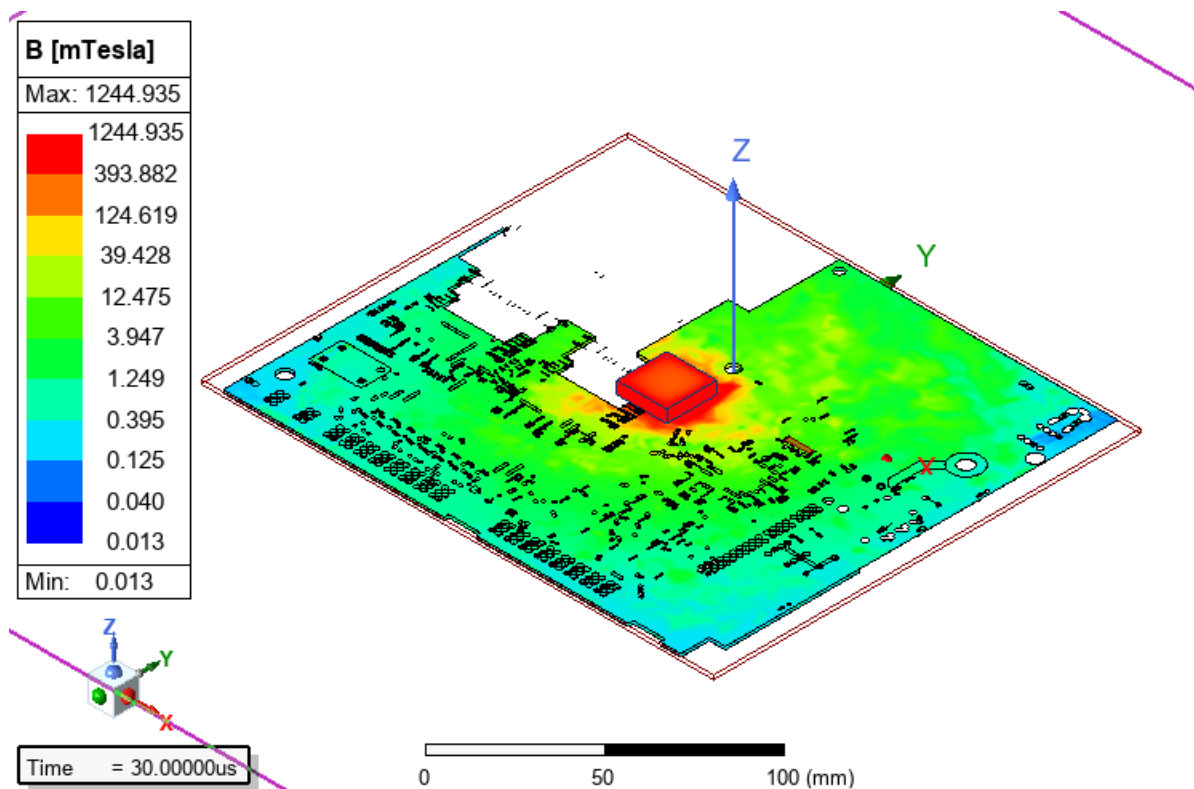

View Field Results on Nets

Next you will plot the flux density and current density results on the GND and VCC nets to see how the magnet affects them.

1. In the Project Manager tree, right click on **Field Overlays** and select **Fields > B > Mag_B**.
2. In the Create Field Plot window:
 - a. Select **Plot on surface only**.
 - b. Click on the **VCC** column label to select all the selectable layers (not all of them are displayed in the illustration).
 - c. Click **Done**.
3. Adjust the time step to 30 us, and set the color key scale to **Log**; if needed, see [Field Visualization](#) for more details.
4. Compare these VCC results with the [field results without the magnet](#).

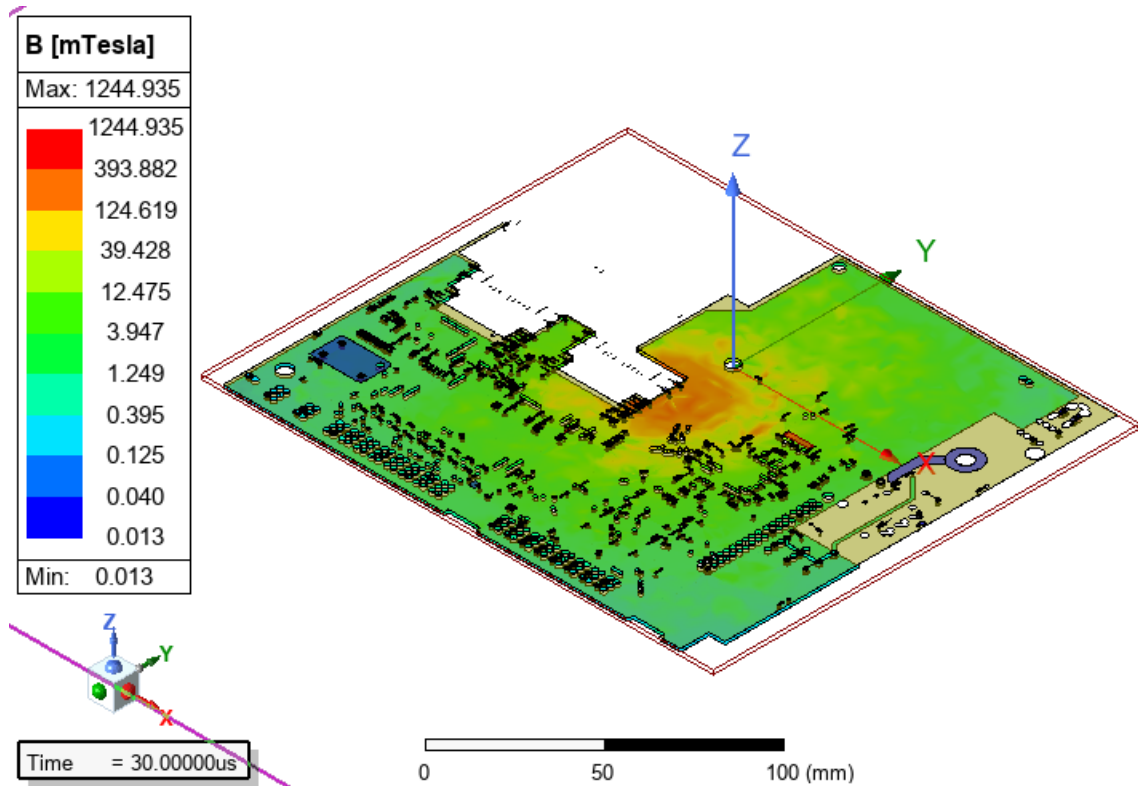

- Plot the **Mag_J** and **J_Vector** results for the VCC net. If needed, see [Field Visualization](#) for more details.

J Magnitude results for VCC:

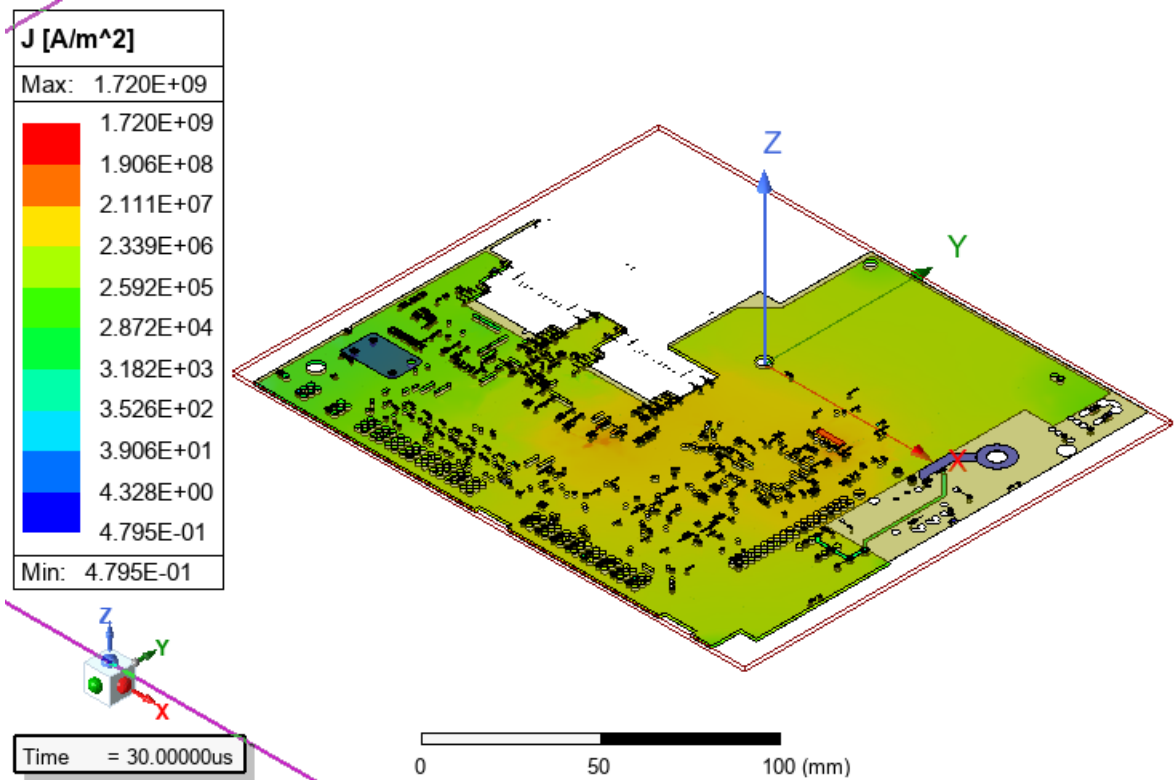

J Vector results for VCC:

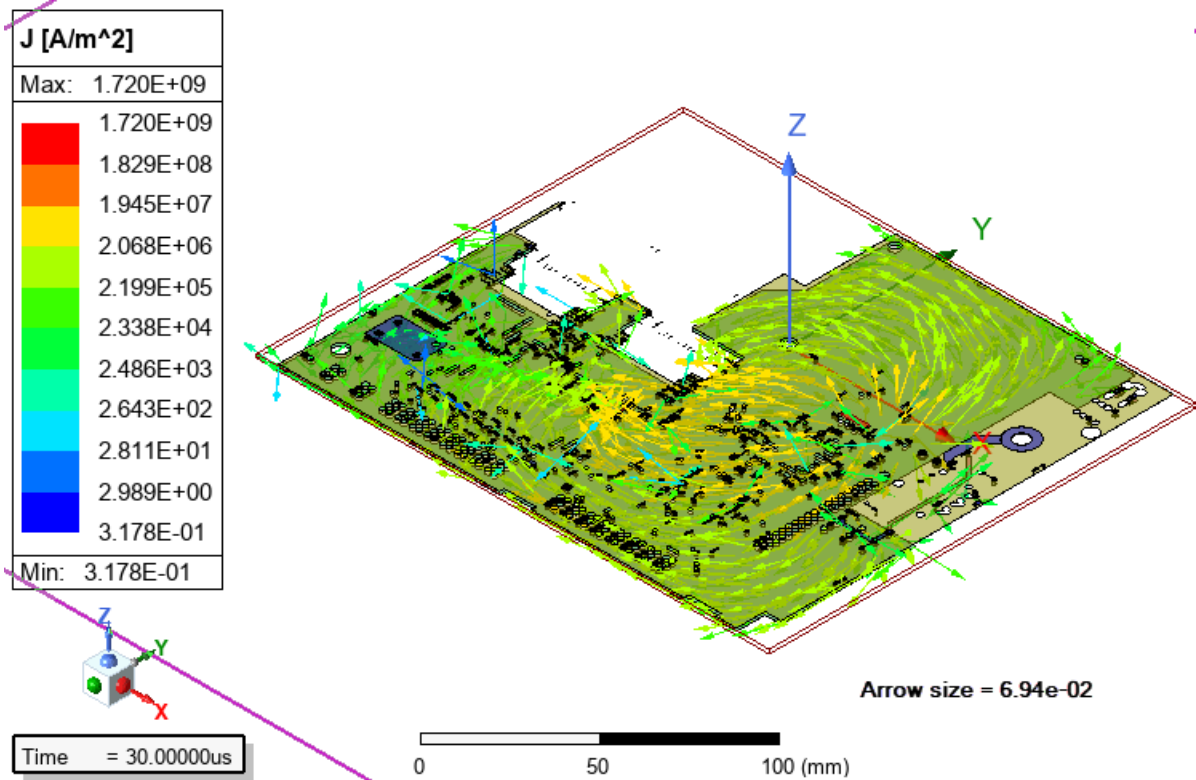

- Plot the **Mag_B**, **J_Mag** and **J_Vector** results for the **GND** net. If needed, see [Field Visualization](#) for more details.

B Magnitude results for GND:

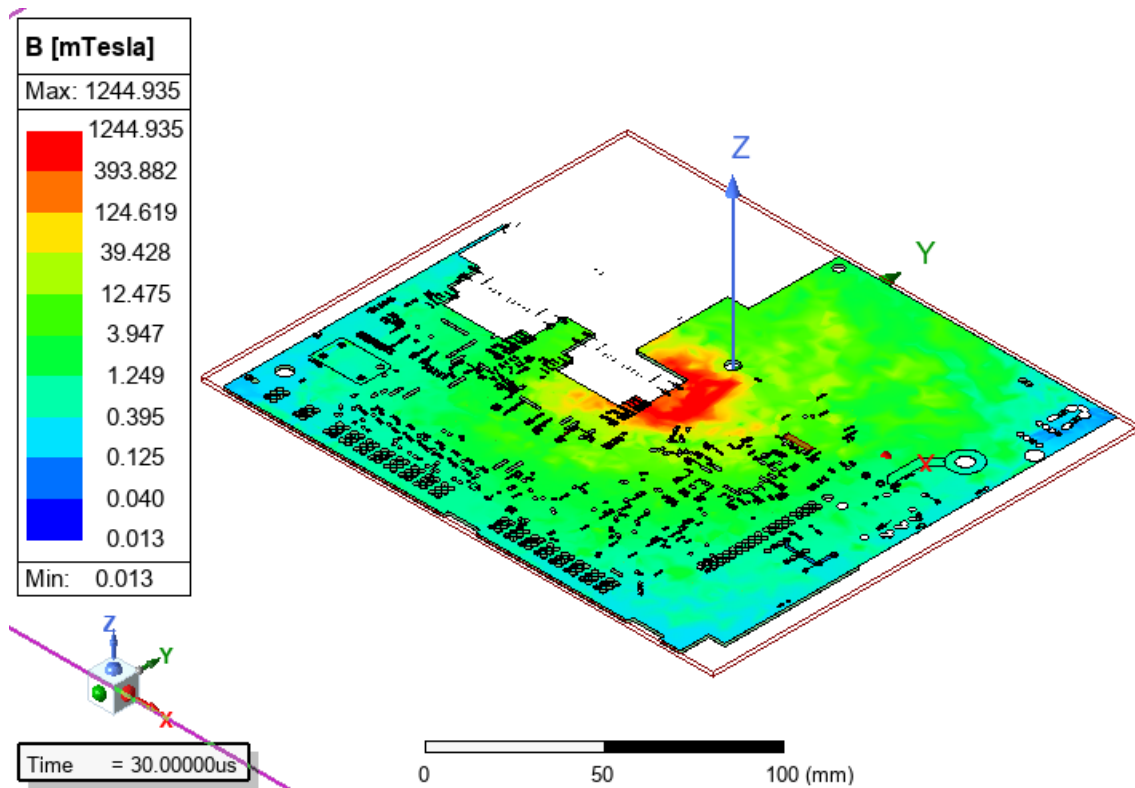

J Magnitude results for GND:

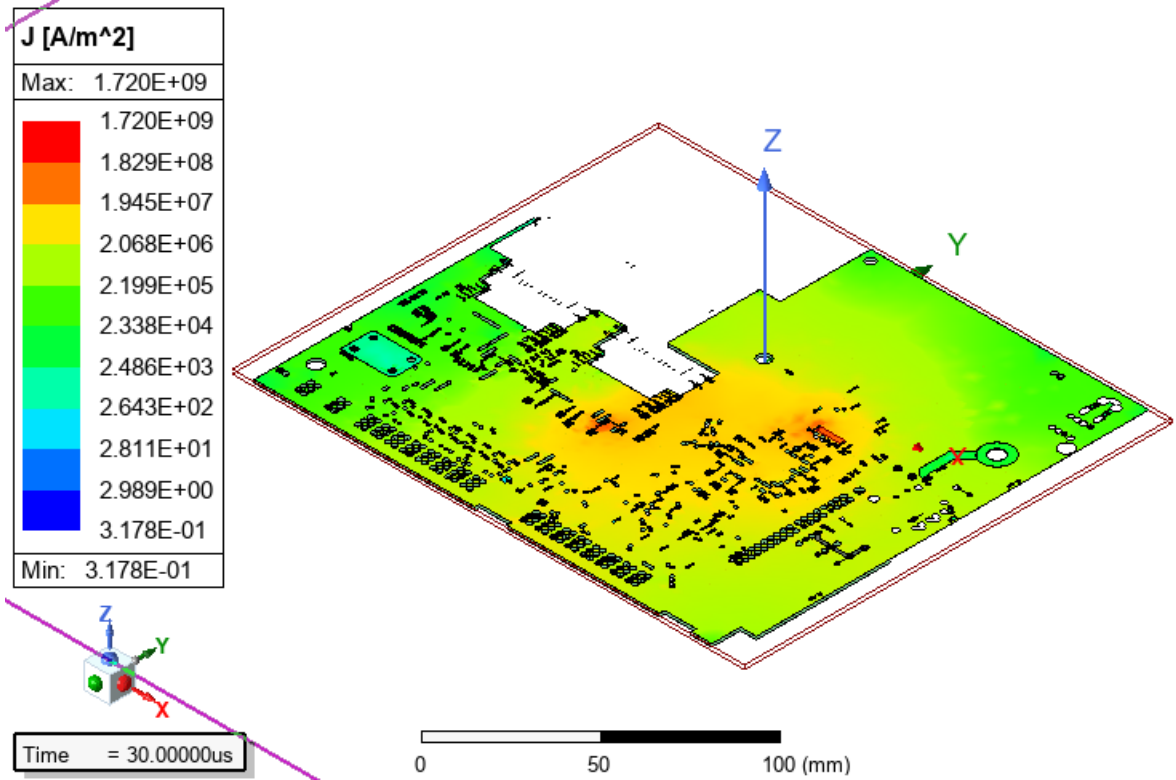

J Vector results for GND:

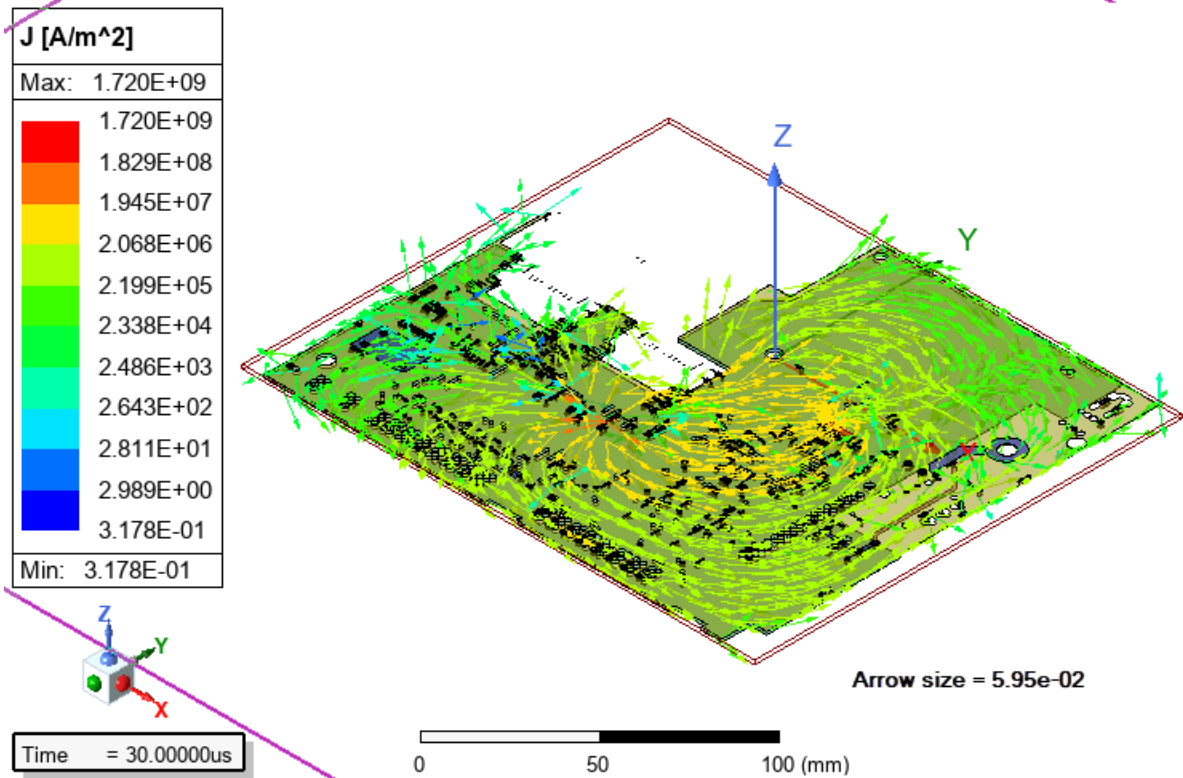

7 - Exit the Electronics Desktop

You have successfully completed the Maxwell-ECAD Integration Getting Started Problem.

1. Save the project plots and reports by clicking **File > Save**. Ansys Electronics Desktop will save all data including the plots you have created for later use.
2. To exit the Ansys Electronics Desktop software, click **File > Exit**.

Index

F

force

- and solution process 4-2
- components of 5-1
- computing for the solenoid core 4-2
- direction of 5-1
- magnitude of 5-1
- viewing solution results 5-1

G

generating a solution 4-1

H

HFSS

- frequency sweep 2-14
- HFSS 3D Layout 2-1
- set up solution 2-14

I

importing a ECAD design 2-1

M

Maxwell

- PCB design 2-9
- Maxwell Field Simulator, exiting 7-1

mesh

- example of 1-1
- use of 1-1

P

- PCB design
- Assign Ports 2-9
- PCB layout 2-1

S

solutions

- calculated values 4-1 , 4-7
- criteria for computing 4-1 , 4-7
- force 5-1 , 5-1
- interpolated values 4-1 , 4-7
- viewing fields 5-1